



the
strength
of 70 years
experience

G E B U W I N
metal products

Company introduction

Gebuwin is a leading manufacturer of high quality hoisting and pulling products. Gebuwin was founded in 1947 by the two brothers Buunk in Winterswijk, the Netherlands. Our products are designed, engineered, assembled and tested within the production facility of over 2000 square meter. With an enthusiastic team of 12 professionals, Gebuwin can operate flexible and therefore ensures that your product is well taken care of.



Gebuwin considers it essential to strive for the highest quality, have an excellent delivery reliability, provide the customer with the best service linked to a competitive price/quality ratio.

Hoisting and lifting capacities go up to 7500 kg in hand operated worm- and spur gear winches. Gebuwin also provides its long term customers in the international offshoring, marine, mining, agriculture and food industry with electrical operated industrial winches and is specialized in custom made hoisting and lifting solutions. In addition, Gebuwin is the right place for punching and turning parts, sub-assemblies and complete end products.

Custom made winches

If a standard winch is not sufficient enough for your application, Gebuwin supplies a custom made winch. A custom made winch is a solution designed according to your specific needs and requirements. This will give you a product ready to use in your application and therefore you will save time and effort.

Our technical experts will support and advise you along the way so you get a custom made solution that perfectly matches your specific requirements.

Are you keen to know what Gebuwin can do for you? Feel free to contact us for more information via info@gebuwin.com or go to www.gebuwin.com.



Table of content

Worm gear winches

• Worm gear winch WW250-1500.....	4
• Worm gear winch WW2000-7500.....	6
• Worm gear winch WW2000-5000 freespool.....	8
• Marine worm gear winch WW1500-5000.....	10
• Webbing belt worm gear winch WB750.....	12

Spur gear winches

• Spur gear winch TL150.....	14
• Spur gear winch TL300-600.....	16
• Spur gear winch TL1000-1500.....	18
• Spur gear winch TC1000-1500 freespool.....	20
• Economy spur gear winch HW200-800.....	22

Electric driven winches

• Electric worm gear winch LS3000-7500 230 V or 400 V - 50Hz.....	24
• Electric worm gear winch EW125-3200 230 V or 400 V - 50 Hz.....	26
• Electric planetary winch EP2000-20000 400 V - 50 Hz.....	28
• Drill worm gear winch DW1000.....	30
• Battery drill worm gear winch WA200.....	32

Other products and accessories

• Electric chain hoist EH125-2000 with eye or hook.....	34
• Electric chain hoist EH125-2000 (electric) trolley.....	36
• Swivel davit SD125-250-500.....	38
• Spur gear box TK1000-1500-1001-1501.....	40
• Pulley block KB150-7500.....	42
• Power tool AM5000-EM5000.....	44
• Wire rope WRH300-7500.....	46



Worm gear winch WW250-1500



Worm gear winch

Product specifications:

- robust and safe hoisting and pulling winch
- in compliance with EN13157, DIN 15020 and EX types ATEX 114 (94/9/EG)
- static safety factor 4
- right angled, easy to grease worm transmission and maintenance free bearings
- cable outlet upwards, downwards or at rear
- adjustable crank, with ergonomic grip
- load pressure brake with double ratchet system
- paint thickness is 60 - 80 micron in 1 layer and in compliance with DIN/ISO 12944, C1M

Options:

- zinc-plated finish (6 - 8 micron)
- ATEX certified  II 3 GD T4, zone 2 and 22
- grooved drum
- crank force limiter
- double cable drum compartments (2D)
- multiple cable drum compartments
- load limiter

Accessories:

- steel or stainless steel wire ropes
- pulley blocks suitable for hand winches
- WW1000 and WW1500 are suitable for winch power tool AM5000 and EM5000



GEBUWIN
metal products

Industrieweg 6, 7102 DZ Winterswijk, The Netherlands
Telephone: +31(0)543 532600 Email: info@gebuwin.com
For more information: www.gebuwin.com



Technical specifications WW250-1500

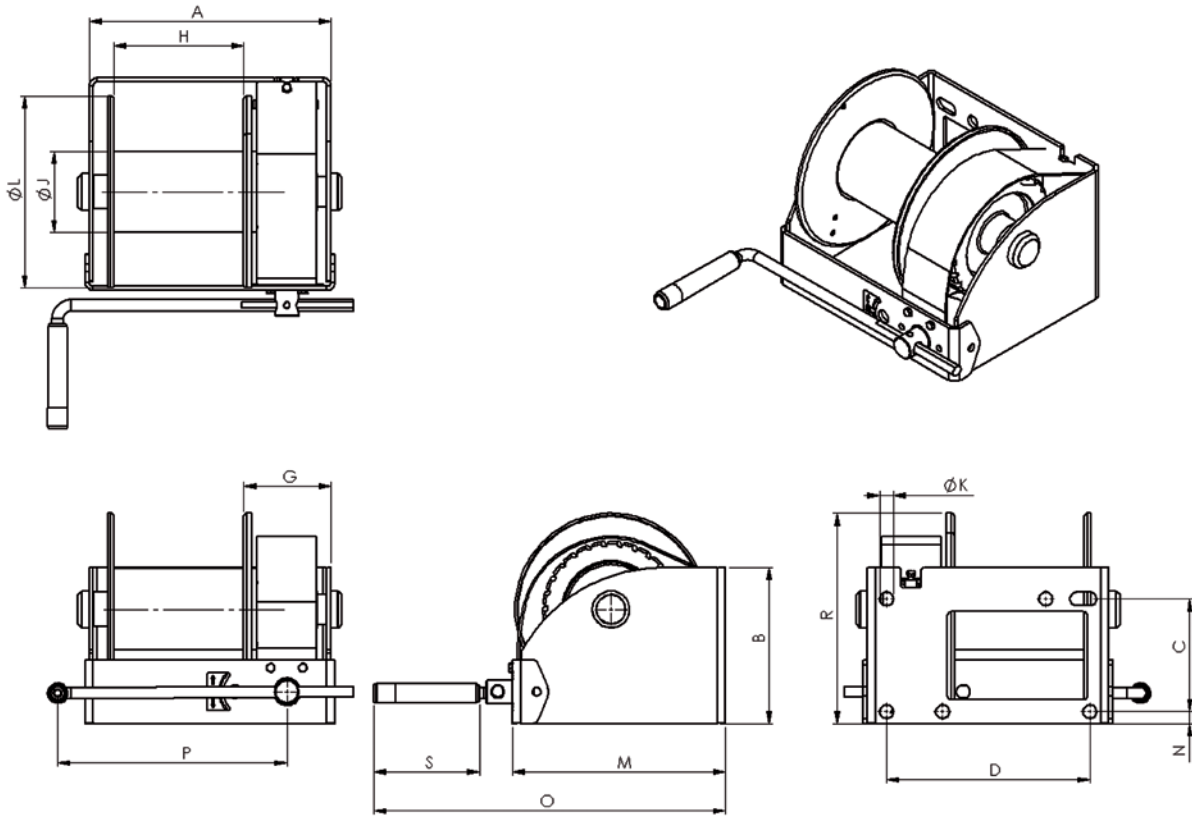

Type	Mounting	Material finish	Remarks
WW250 - 1500 GR / D	Wall, 4x M12 class 8.8	Painted finish	RAL 7035 (grey)
WW250 - 1500 EV / D	Wall, 4x M12 class 8.8	Zinc-plated finish	
WW250 - 1500 GR / 2D	Wall, 4x M12 class 8.8	Painted finish	RAL 7035 (grey)
WW250 - 1500 EV / 2D	Wall, 4x M12 class 8.8	Zinc-plated finish	

Dimensions	A	B	C	D	G	H	H	J	K	L	M	N	O	P	R	S
(mm)						(D)	(2D)									
WW250	238	145	100	192	107	105	2 x 47	48	14	160	191	15	365	280	171	132
WW500	269	160	115	223	108	135	2 x 62	70	14	190	221	15	393	325	193	132
WW1000	302	195	141	254	109	162	2 x 73	102	17	240	266	15	440	350	263	132
WW1500	302	250	178	254	109	162	2 x 73	102	17	240	278	15	451	350	306	132

Technical specifications		WW250	WW500	WW1000	WW1500
Capacity 1st cable layer (D)	kg	250	500	1000	1500
Capacity 1st cable layer (2D)	kg	2 x 125	2 x 250	2 x 500	2 x 750
Capacity last cable layer (D)	kg	92	224	527	846
Capacity last cable layer (2D)	kg	2 x 46	2 x 104	2 x 243	2 x 399
Crankforce 1st cable layer	daN	6	10	13	14
Hoisting length one rotation, 1st layer	mm	17	20	13	9
Max. cable storage, one cable drum (D)	m	104	78	63	41
Max. cable storage, per drum comp. (2D)	m	44	84	64	28
Diameter cable (D)	mm	4	6	8	10
Diameter cable (2D)	mm	4	4	6	8
Min. breaking load cable (D)	kN	7,5	15	30	45
Min. breaking load cable (2D)	kN	4	7,5	15	22,5
Own weight	kg	10	13	22	24

subject to changes

For more information: www.gebuwin.com

Worm gear winch WW2000-7500



Worm gear winch

Product specifications:

- robust and safe hoisting and pulling winch with two speeds
- in compliance with EN13157, DIN 15020 and EX types ATEX 114 (94/9/EG)
- static safety factor 4
- right angled, easy to grease worm transmission and maintenance free bearings
- cable outlet upwards, downwards or at rear
- adjustable crank, with ergonomic grip
- load pressure brake with double ratchet system
- paint thickness is 60 - 80 micron in 1 layer and in compliance with DIN/ISO 12944, C1M

Options:

- zinc-plated finish (6 - 8 micron)
- ATEX certified Ex II 3 GD T4, zone 2 and 22
- grooved drum
- double cable drum compartments (2D)
- multiple cable drum compartments

Accessories:

- steel or stainless steel wire ropes
- pulley blocks suitable for hand winches
- suitable for winch powertool AM5000 and EM5000



GEBUWIN
metal products

Industrieweg 6, 7102 DZ Winterswijk, The Netherlands
Telephone: +31(0)543 532600 Email: info@gebuwin.com
For more information: www.gebuwin.com



Technical specifications WW2000-7500

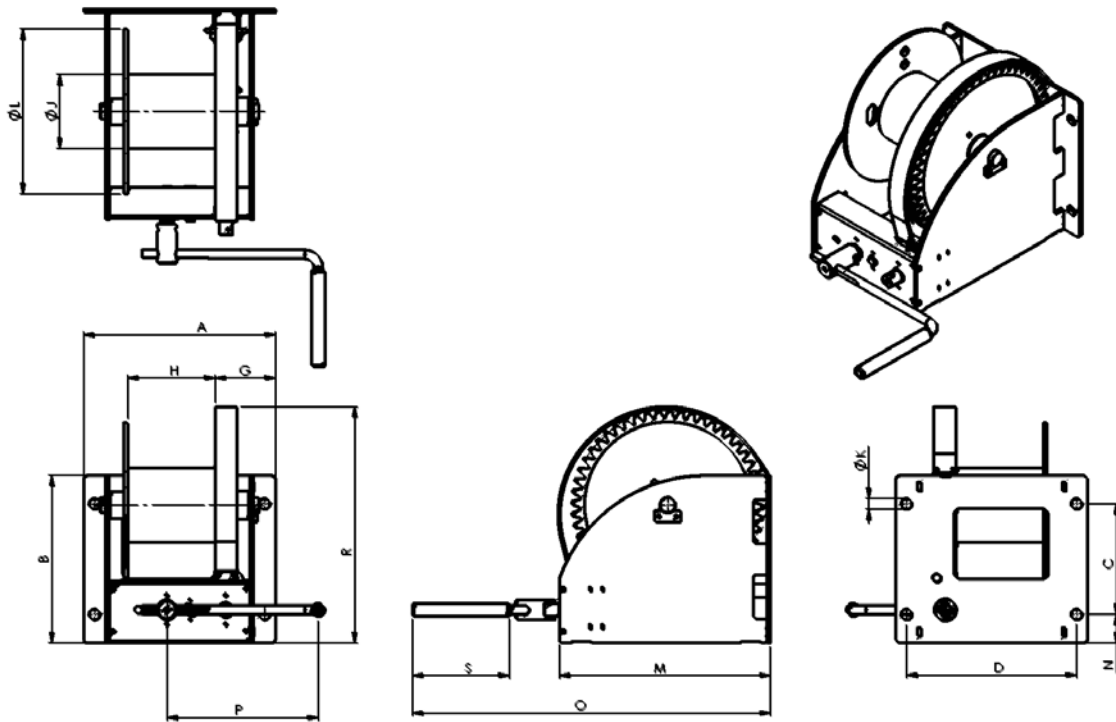

Type	Mounting	Material finish	Remarks
WW2000 - 7500 GR / D	Wall, 4x M20 class 8.8	Painted finish	RAL 7035 (grey)
WW2000 - 7500 EV / D	Wall, 4x M20 class 8.8	Zinc-plated finish	
WW2000 - 5000 GR / 2D	Wall, 4x M20 class 8.8	Painted finish	RAL 7035 (grey)
WW2000 - 5000 EV / 2D	Wall, 4x M20 class 8.8	Zinc-plated finish	

Dimensions	A	B	C	D	G	H	H	J	K	L	M	N	O	P	R	S	
(mm)					(D)		(2D)										
WW2000	410	310	196	360	137	177	2 x 86	133	25	312	372	57	705	380	434	220	
WW3000	436	380	251	386	137	203	2 x 99	168	25	375	480	65	813	380	536	220	
WW4000	436	380	251	386	137	203	2 x 99	168	25	375	480	65	813	380	536	220	
WW5000	436	467	316	386	137	200	2 x 96	219	25	437	515	75	847	380	618	220	
WW7500	510	500	350	455	189	202	-	245	25	437	630	75	968	380	748	220	

Technical specifications		WW2000	WW3000	WW4000	WW5000	WW7500
Capacity 1st cable layer (D)	kg	2000	3000	4000	5000	7500
Capacity 1st cable layer (2D)	kg	2 x 1000	2 x 1500	2 x 2000	2 x 2500	-
Capacity last cable layer (D)	kg	1038	1667	2282	3276	3748
Capacity last cable layer (2D)	kg	2 x 519	2 x 833	2 x 1141	2 x 1638	-
Crankforce 1st cable layer	daN	24 (11)	31 (14)	30 (13)	73 (14)	78 (15)
Hoisting length one rotation, 1st layer	mm	12 (5)	11 (5)	11 (2)	13 (3)	11 (2)
Max. cable storage, one cable drum (D)	m	75	68	53	43	72
Max. cable storage, per drum comp. (2D)	m	68	66	53	35	-
Diameter cable (D)	mm	12	14	16	18	22
Diameter cable (2D)	mm	8	10	11	14	-
Min. breaking load cable (D)	kN	60	90	120	150	225
Min. breaking load cable (2D)	kN	30	45	60	75	-
Own weight	kg	60	78	80	117	190

subject to changes

Form more information: www.gebuwin.com

Worm gear winch WW2000-5000 freespool

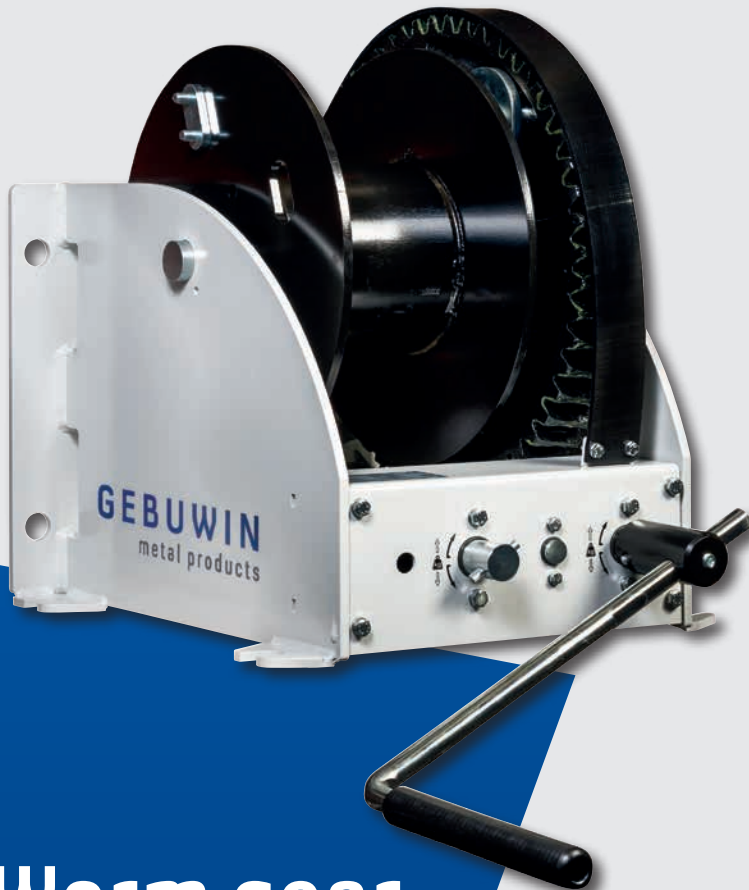

Worm gear free spool winch

Product specifications:

- robust and safe hoisting or pulling winch with two speeds
- free spooling cable drum designed especially for pulling applications
- pulling capacity is approx. 2,5x hoisting capacity
- in compliance with EN13157, DIN 15020 and EX types ATEX 114 (94/9/EG)
- static safety factor 4
- right angled, easy to grease worm transmission and maintenance free bearings
- cable outlet upwards, downwards or at rear
- adjustable crank, with ergonomic grip
- load pressure brake with double ratchet system
- paint thickness is 60 - 80 micron in 1 layer and in compliance with DIN/ISO 12944, C1M

Options:

- adjustable friction brake for controlled cable unwinding (will lead to different dimensions of the winch)
- zinc-plated finish (6 - 8 micron)
- ATEX certified Ex II 3 GD T4, zone 2 and 22
- grooved drum
- double cable drum compartments (2D)
- multiple cable drum compartments

Accessories:

- steel or stainless steel wire ropes
- pulley blocks suitable for hand winches
- suitable for winch powertool AM5000 and EM5000



GEBUWIN
metal products

Industrieweg 6, 7102 DZ Winterswijk, The Netherlands
Telephone: +31(0)543 532600 Email: info@gebuwin.com
For more information: www.gebuwin.com



Technical specifications WW2000-5000 / FS

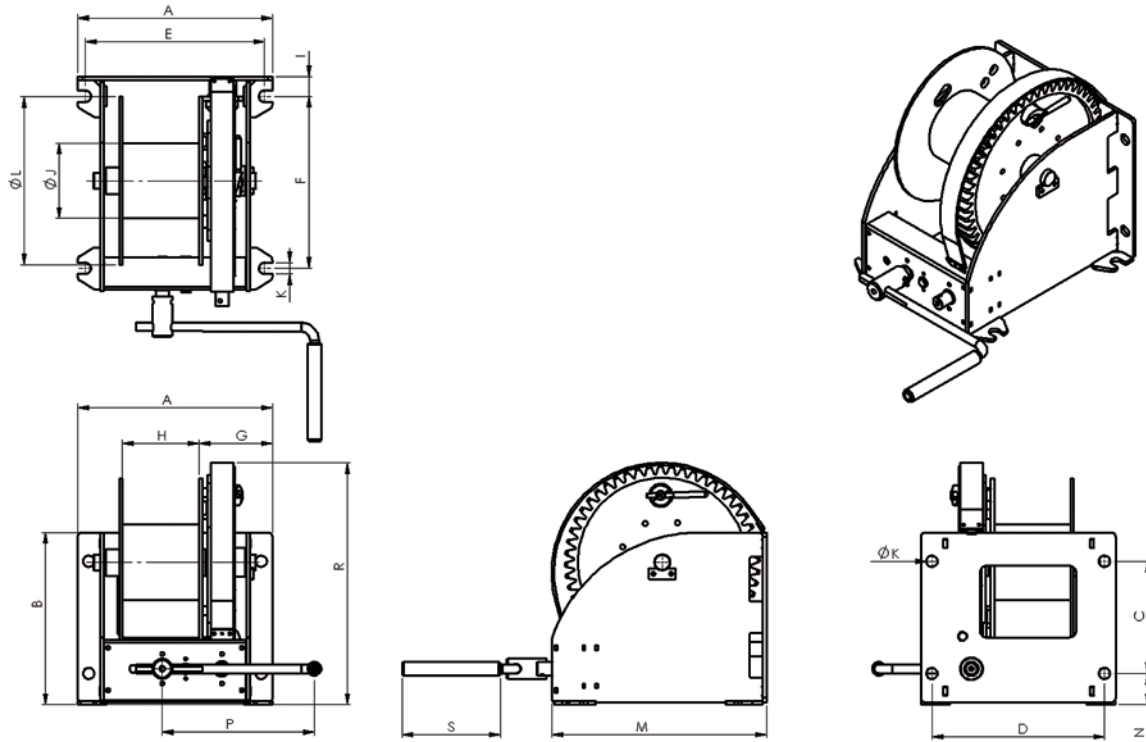

Type	Mounting	Material finish	Remarks
WW2000 - 5000 GR / D / FS	Wall / Floor, 4x M20 class 8.8	Painted finish	RAL 7035 (grey)
WW2000 - 5000 EV / D / FS	Wall / Floor, 4x M20 class 8.8	Zinc-plated finish	

Dimensions (mm)	A	B	C	D	E	F	G	H	I	J	K	L	M	N	P	R	S
WW2000	410	310	196	360	376	279	166	147	42	133	25	312	372	62	380	437	220
WW3000	436	385	251	386	401	385	164	172	44	168	25	375	480	70	380	541	220
WW4000	436	385	251	386	401	385	164	172	44	168	25	375	480	70	380	541	220
WW5000	436	372	316	386	401	420	171	168	44	219	25	437	515	80	380	625	220

Technical specifications		WW2000	WW3000	WW4000	WW5000
Capacity 1st cable layer	kg	2000	3000	4000	5000
Capacity last cable layer	kg	1038	1667	2282	3276
Crankforce 1st cable layer	daN	24 (11)	31 (14)	30 (13)	73 (14)
Hoisting length one rotation, 1st layer	mm	12 (5)	11 (5)	11 (2)	13 (3)
Max. cable storage (one cable drum)	m	59	57	43	33
Diameter cable	mm	12	14	16	18
Min. breaking load cable	kN	60	90	120	150
Own weight	kg	63	82	84	122

subject to changes

Form more information: www.gebuwin.com

Marine worm gear winch WW1500-5000

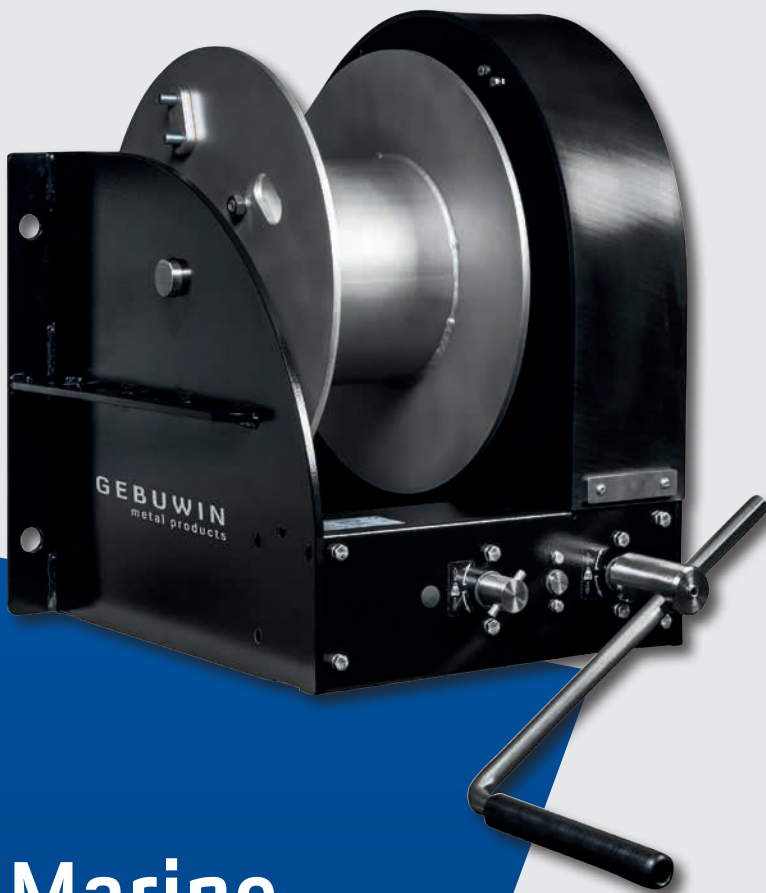

Marine worm gear winch

Product specifications:

- robust and safe hoisting and pulling winch with two speeds for the WW3000-5000
- in compliance with EN13157, DIN 15020 and EX types ATEX 114 (94/9/EG)
- static safety factor 4
- right angled, easy to grease worm transmission and maintenance free bearings
- cable outlet upwards, downwards or at rear
- adjustable crank, with ergonomic grip
- load pressure brake with double ratchet system
- transmission is entirely enclosed and protected against environmental influence with protection classification IP54
- cable drum, crank and all extruding shafts are made of stainless steel SAE grade 316
- all fasteners are made of stainless steel A4
- winch frame is made of steel, surfaces are brushed and edges are rounded
- paint thickness is 240 micron in 3 layers and in compliance with DIN/ISO 12944, C5M

Options:

- ATEX certified  II 3 GD T4, zone 2 and 22
- grooved drum
- multiple cable drum compartments

Accessories:

- stainless steel wire ropes
- pulley blocks suitable for hand winches
- suitable for winch powertool AM5000 and EM5000



GEBUWIN
metal products

Industrieweg 6, 7102 DZ Winterswijk, The Netherlands
Telephone: +31(0)543 532600 Email: info@gebuwin.com
For more information: www.gebuwin.com



Technical specifications WW1500 / MR

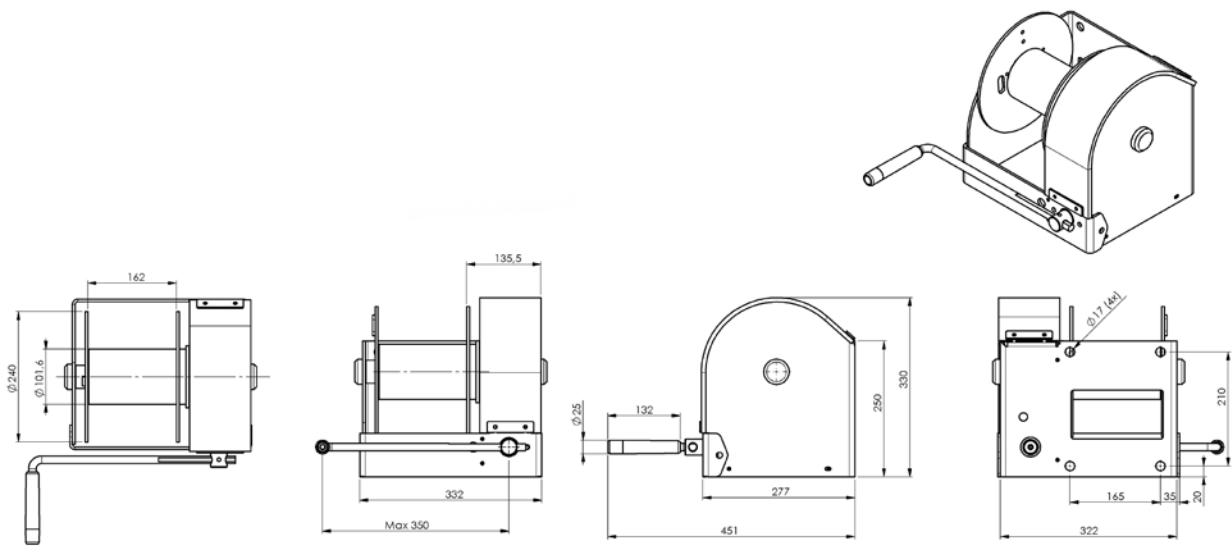

Technical specifications WW3000-5000 / MR

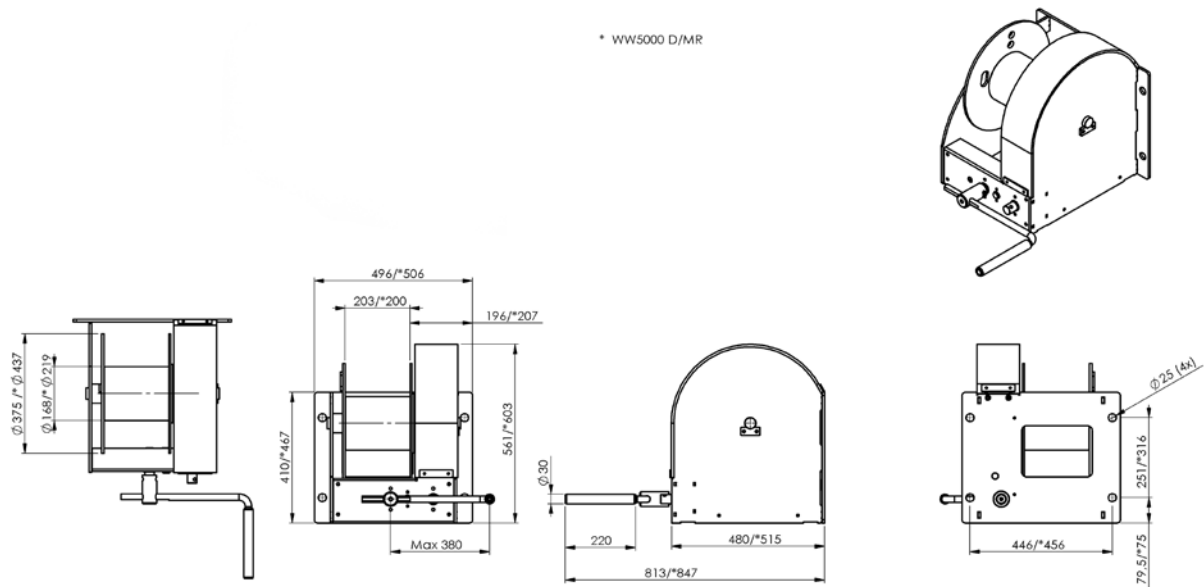

Type	Mounting	Material finish	Remarks
WW1500 D / MR	Wall, 4x M16 class 8.8	Painted / Stainless steel 316	RAL 9005 (black)
WW3000 D / MR	Wall, 4x M20 class 8.8	Painted / Stainless steel 316	RAL 9005 (black)
WW5000 D / MR	Wall, 4x M20 class 8.8	Painted / Stainless steel 316	RAL 9005 (black)

Technical specifications	WW1500	WW3000	WW5000
Capacity 1st cable layer	1500 kg	3000 kg	5000 kg
Capacity last cable layer	846 kg	1667 kg	3276 kg
Crankforce 1st cable layer	14 daN	31 (14) daN	73 (14) daN
Hoisting length one rotation, 1st layer	9 mm	11 (5) mm	13 (3) mm
Max. cable storage (one cable drum)	41 m	68 m	43 m
Diameter cable	10 mm	14 mm	18 mm
Min. breaking load cable	45 kN	90 kN	160 kN
Own weight	30 kg	104 kg	135 kg

subject to changes

Form more information: www.gebuwin.com

Webbing belt winch WB750



Webbing belt worm gear winch

Product specifications:

- robust and safe hoisting and pulling winch
- pulling capacity is approx. 2,5x hoisting capacity
- static safety factor 4
- thin webbing belt instead of cable makes the winch very compact
- winch is excluded webbing belt
- belt outlet upwards, downwards or at rear
- right angled, easy to grease worm transmission and maintenance free bearings
- adjustable crank with ergonomic grip
- load pressure brake with double ratchet system
- paint thickness is 60 - 80 micron in 1 layer and in compliance with DIN/ISO 12944, C1M
- in compliance with EN13157 and DIN 15020

Options:

- zinc-plated finish (6 - 8 micron)

Accessories:

- webbing belt
- pulley blocks suitable for hand winches

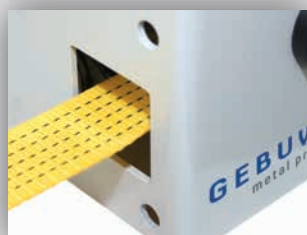

GEBUWIN
metal products

Industrieweg 6, 7102 DZ Winterswijk, The Netherlands
Telephone: +31(0)543 532600 Email: info@gebuwin.com
For more information: www.gebuwin.com



Technical specifications WB750

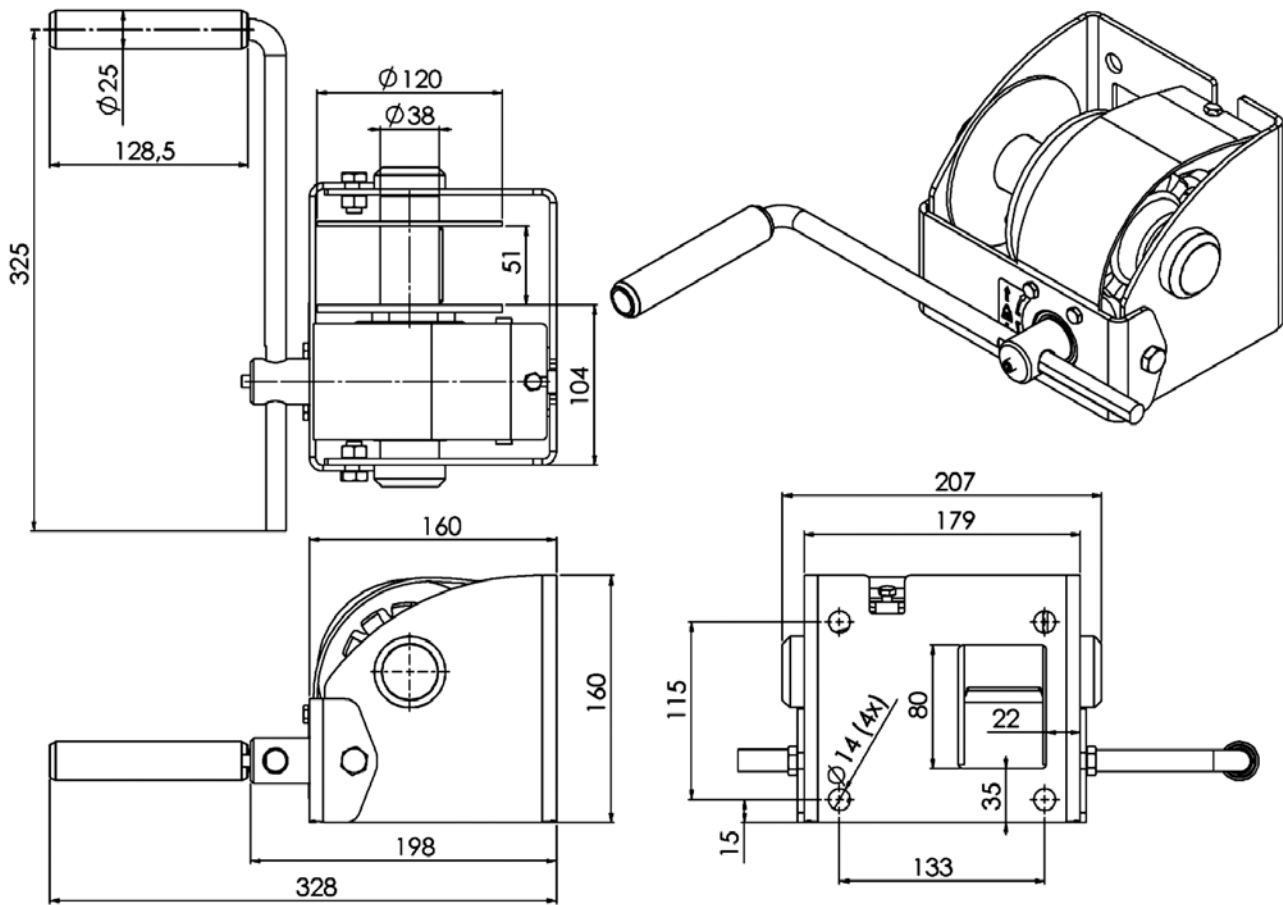

Type	Mounting	Material finish	Remarks
WB750 GR	Wall, 4x M12 class 8.8	Painted finish	RAL 7035 (grey), excluding webbing belt
WB750 EV	Wall, 4x M12 class 8.8	Zinc-plated finish	Excluding webbing belt

Technical specifications			WB750
Capacity 1st belt layer	kg		750
Capacity last belt layer	kg		350
Crankforce 1st belt layer	daN		11
Hoisting length one rotation, 1st layer	mm		12
Max. belt storage	m		5
Width belt	mm		max. 50
Min. breaking load belt	kN		37,5
Own weight	kg		9

subject to changes

Form more information: www.gebuwin.com

Spur gear winch TL150

Spur gear winch



Product specifications:

- robust and safe hoisting winch
- static safety factor 4
- load pressure brack with double ratchet system
- maintenance free bearing
- cable outlet left or right
- adjustable crank with ergonomic grip
- in compliance with EN13157, DIN 15020 and EX types ATEX 114 (94/9/EG)
- paint thickness is 60 - 80 micron in 1 layer and in compliance with DIN/ISO 12944, C1M

Options:

- zinc-plated finish (6 - 8 micron)
- ATEX certified  II 3 GD T3, zone 2 and 22

Accessories:

- steel or stainless steel wire ropes
- pulley blocks suitable for hand winches



GEBUWIN
metal products

Industrieweg 6, 7102 DZ Winterswijk, The Netherlands
Telephone: +31(0)543 532600 Email: info@gebuwin.com
For more information: www.gebuwin.com



Technical specifications TL150

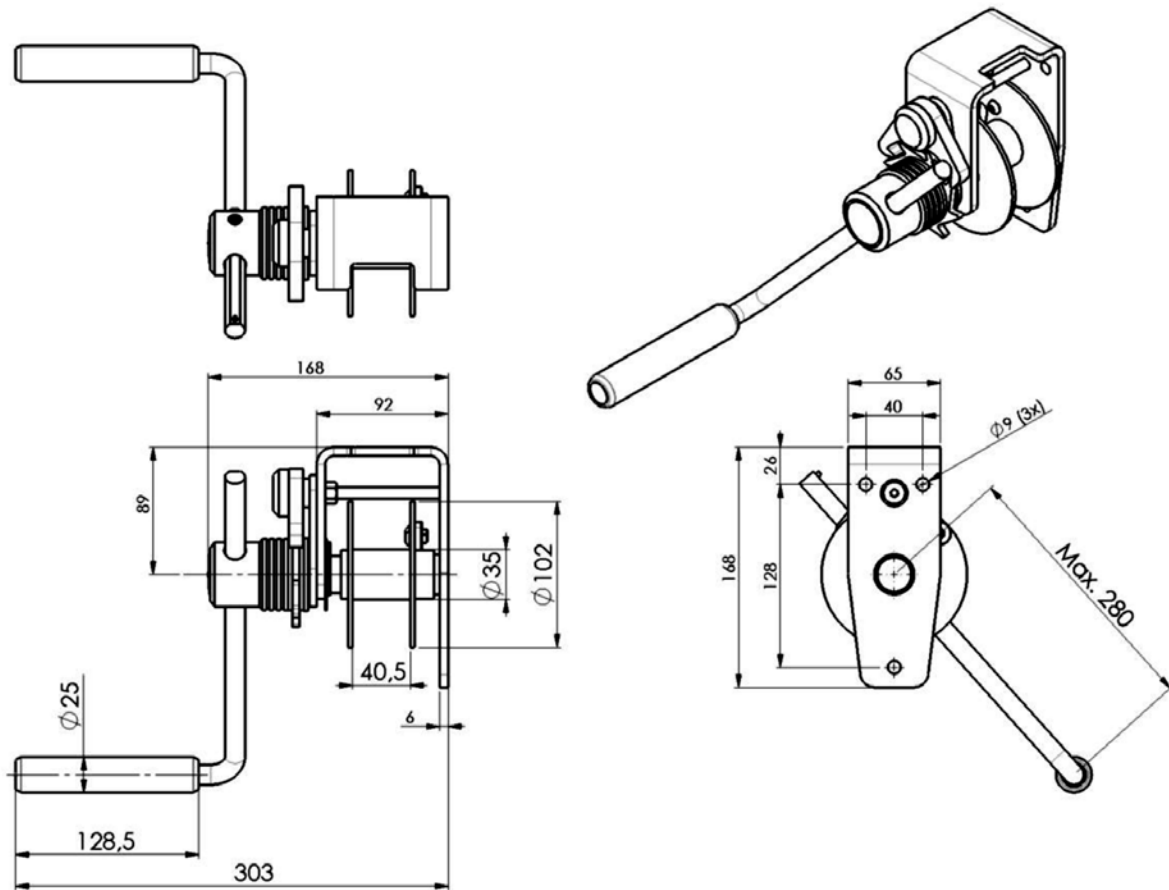

Type	Mounting	Material finish	Remarks
TL150 GR	Wall, 3x M8 class 8.8	Painted finish	RAL 7035 (grey)
TL150 EV	Wall, 3x M8 class 8.8	Zinc-plated finish	

Technical specifications			TL150
Capacity 1st cable layer	kg		150
Capacity last cable layer	kg		68
Crankforce 1st cable layer	daN		11
Hoisting length one rotation, 1st layer	mm		122
Max. cable storage (one cable drum)	m		13
Diameter cable	mm		4
Min. breaking load cable	kN		4,5
Own weight	kg		4

subject to changes

Form more information: www.gebuwin.com

Spur gear winch TL300-600



Spur gear winch

Product specifications:

- robust and safe hoisting winch
- static safety factor 4
- load pressure brake with double ratchet system
- maintenance free bearings
- adjustable crank with ergonomic grip
- cable outlet upwards
- in compliance with EN13157, DIN 15020 and EX types ATEX 114 (94/9/EG)
- paint thickness is 60 - 80 micron in 1 layer and in compliance with DIN/ISO 12944, C1M

Options:

- zinc-plated finish (6 - 8 micron)
- ATEX certified  II 3 GD T3, zone 2 and 22

Accessories:

- steel or stainless steel wire ropes
- pulley blocks suitable for hand winches



GEBUWIN
metal products

Industrieweg 6, 7102 DZ Winterswijk, The Netherlands
Telephone: +31(0)543 532600 Email: info@gebuwin.com
For more information: www.gebuwin.com



Technical specifications TL300-600

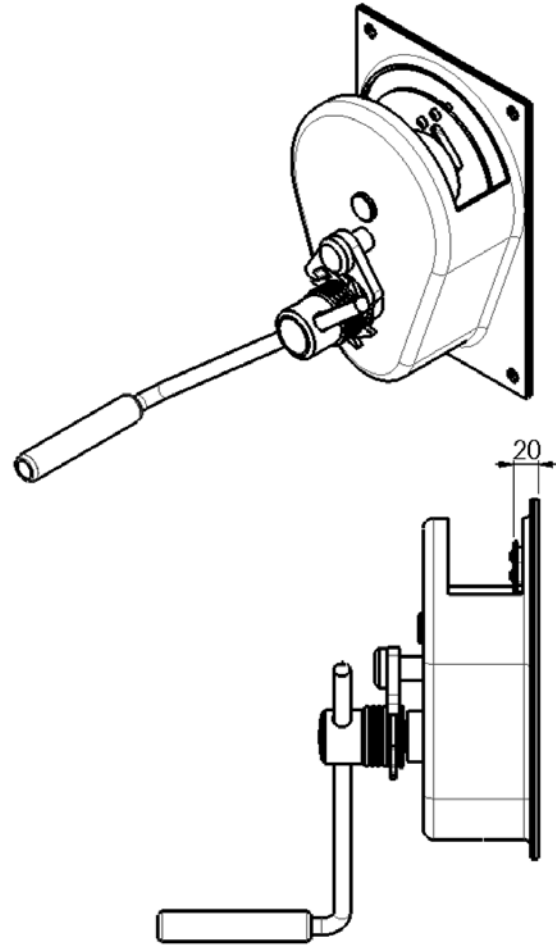
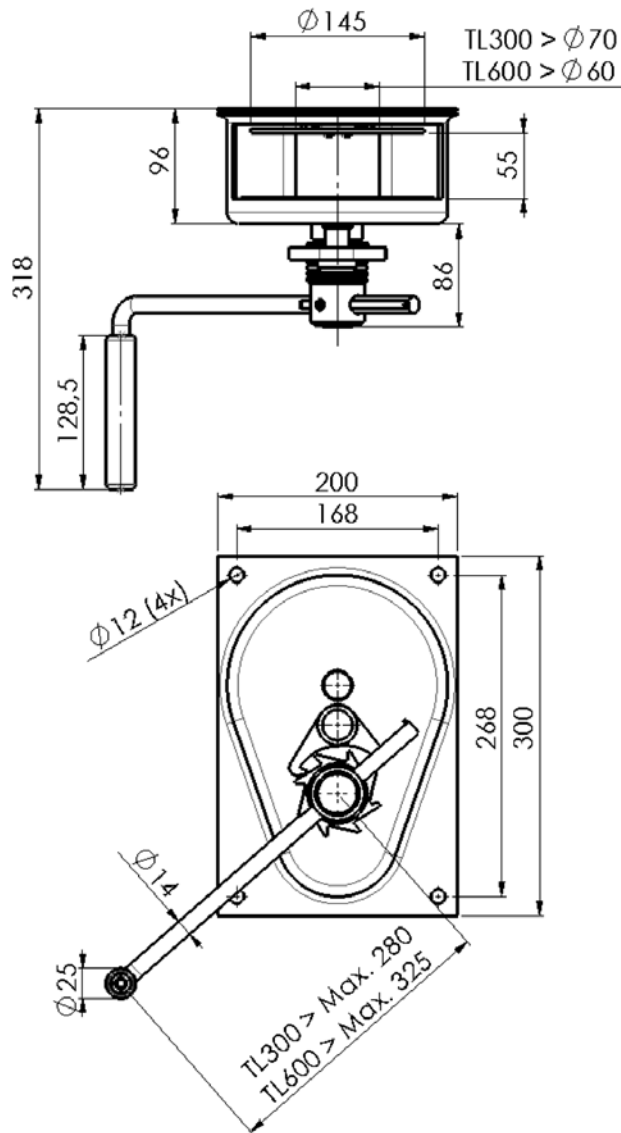

Type	Mounting	Material finish	Remarks
TL300 - 600 GR	Wall, 4x M8 class 8.8	Painted finish	RAL 7035 (grey)
TL300 - 600 EV	Wall, 4x M8 class 8.8	Zinc-plated finish	

Technical specifications		TL300	TL600
Capacity 1st cable layer	kg	300	600
Capacity last cable layer	kg	172	336
Crankforce 1st cable layer	daN	6	10
Hoisting length one rotation, 1st layer	mm	32	28
Max. cable storage (one cable drum)	m	35	12
Diameter cable	mm	4	6
Min. breaking load cable	kN	9	18
Own weight	kg	10	11

subject to changes

Form more information: www.gebuwin.com

Spur gear winch TL1000-1500



Spur gear winch

Product specifications:

- robust and safe hoisting winch
- static safety factor 4
- load pressure brake with double ratchet system
- maintenance free bearings
- adjustable crank with ergonomic grip
- cable outlet upwards, downwards or at the left
- closed gearbox
- in compliance with EN13157, DIN 15020 and EX types ATEX 114 (94/9/EG)
- paint thickness is 60 - 80 micron in 1 layer and in compliance with DIN/ISO 12944, C1M

Options:

- stainless steel SAE grade 304
- ATEX certified  II 3 GD T3, zone 2 and 22
- multiple cable drum compartments

Accessories:

- steel or stainless steel wire ropes
- pulley blocks suitable for hand winches

GEBUWIN
metal products

Industrieweg 6, 7102 DZ Winterswijk, The Netherlands
Telephone: +31(0)543 532600 Email: info@gebuwin.com
For more information: www.gebuwin.com



Technical specifications TL1000-1500

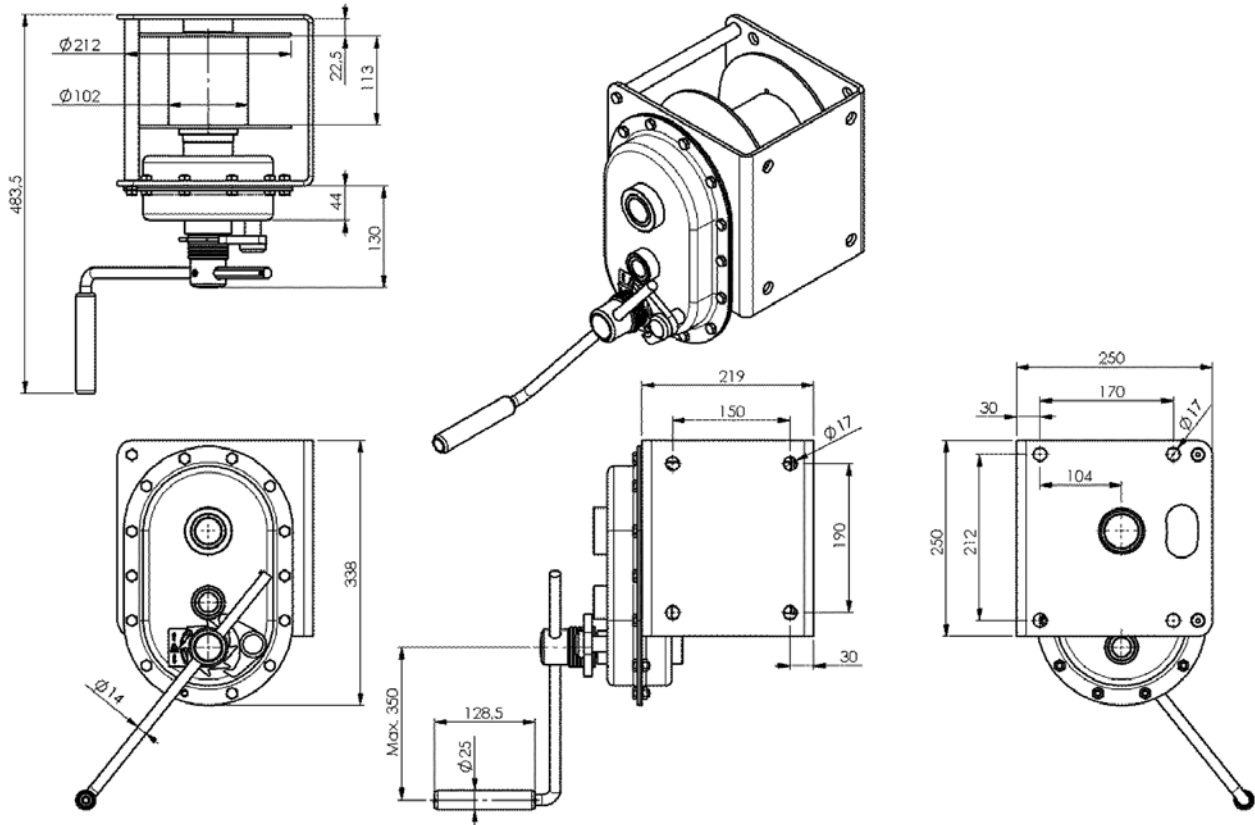

Type	Mounting	Material finish	Remarks
TL1000 - 1500 GR	Wall, 4x M12 class 8.8	Painted finish	RAL 7035 (grey)
TL1000 - 1500 SS	Wall, 4x M12 class 8.8	Stainless steel	

Technical specifications		TL1000	TL1500
Capacity 1st cable layer	kg	1000	1500
Capacity last cable layer	kg	614	927
Crankforce 1st cable layer	daN	11	12
Hoisting length one rotation, 1st layer	mm	20	14
Max. cable storage (one cable drum)	m	33	21
Diameter cable	mm	8	10
Min. breaking load cable	kN	30	45
Own weight	kg	27	27,5

subject to changes

Form more information: www.gebuwin.com

Spur gear winch TC1000-1500 freespool



Spur gear console winch

Product specifications:

- robust and safe pulling and hoisting winch
- pulling capacity is approx. 2,5x hoisting capacity
- static safety factor 4
- load pressure brake with double ratchet system
- maintenance free bearings
- adjustable crank with ergonomic grip
- cable outlet upwards, left or right
- closed gearbox
- with free spool lever (FS)
- in compliance with EN13157, DIN 15020 and EX types ATEX 114 (94/9/EG)
- paint thickness is 60 - 80 micron in 1 layer and in compliance with DIN/ISO 12944, C1M

Options:

- stainless steel SAE grade 304
- ATEX certified Ex II 3 GD T3, zone 2 and 22
- multiple cable drum compartments

Accessories:

- steel or stainless steel wire ropes
- pulley blocks suitable for hand winches



GEBUWIN
metal products

Industrieweg 6, 7102 DZ Winterswijk, The Netherlands
Telephone: +31(0)543 532600 Email: info@gebuwin.com
For more information: www.gebuwin.com



Technical specifications TC1000-1500 / FS

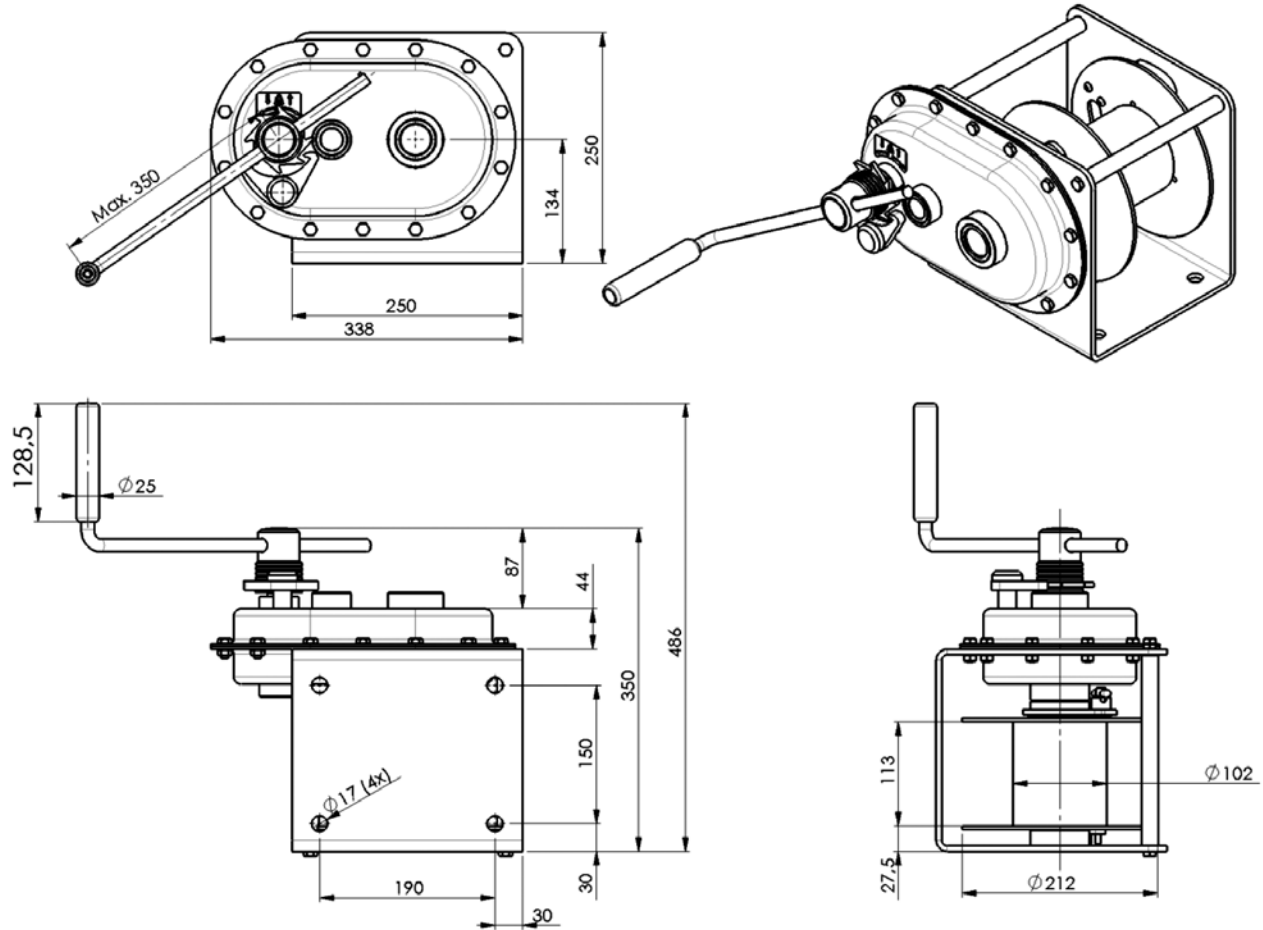

Type	Mounting	Material finish	Remarks
TC1000 - 1500 GR / FS	Console, 4x M12 class 8.8	Painted finish	RAL 7035 (grey)
TC1000 - 1500 SS / FS	Console, 4x M12 class 8.8	Stainless steel 304	

Technical specifications		TC1000	TC1500
Capacity 1st cable layer	kg	1000	1500
Capacity last cable layer	kg	614	927
Crankforce 1st cable layer	daN	11	12
Hoisting length one rotation, 1st layer	mm	20	14
Max. cable storage (one cable drum)	m	33	21
Diameter cable	mm	8	10
Min. breaking load cable	kN	30	45
Own weight	kg	27	27,5

subject to changes

Form more information: www.gebuwin.com

Economy class spur gear winch HW200-800



Economy class spur gear winch



Product specifications:

- safe hoisting and pulling winch
- load pressure brake with ratchet system
- maintenance free bearings
- ergonomic grip
- in compliance DIN 15020
- static safety factor 1,5

Options:

- stainless steel version SAE grade 304

Accessories:

- steel or stainless steel wire ropes
- pulley blocks suitable for hand winches

GEBUWIN
metal products

Industrieweg 6, 7102 DZ Winterswijk, The Netherlands
Telephone: +31(0)543 532600 Email: info@gebuwin.com
For more information: www.gebuwin.com



Technical specifications HW200

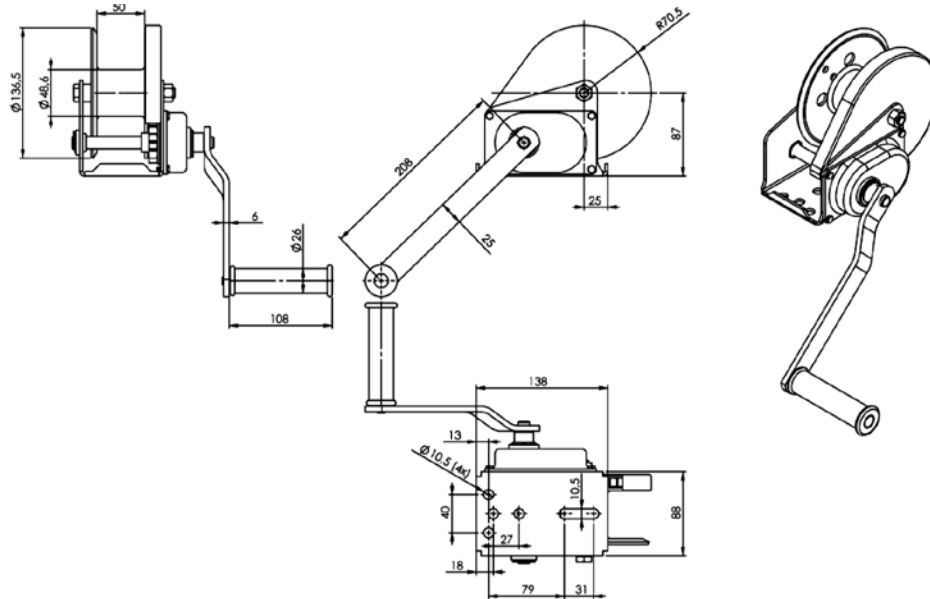

Technical specifications HW800

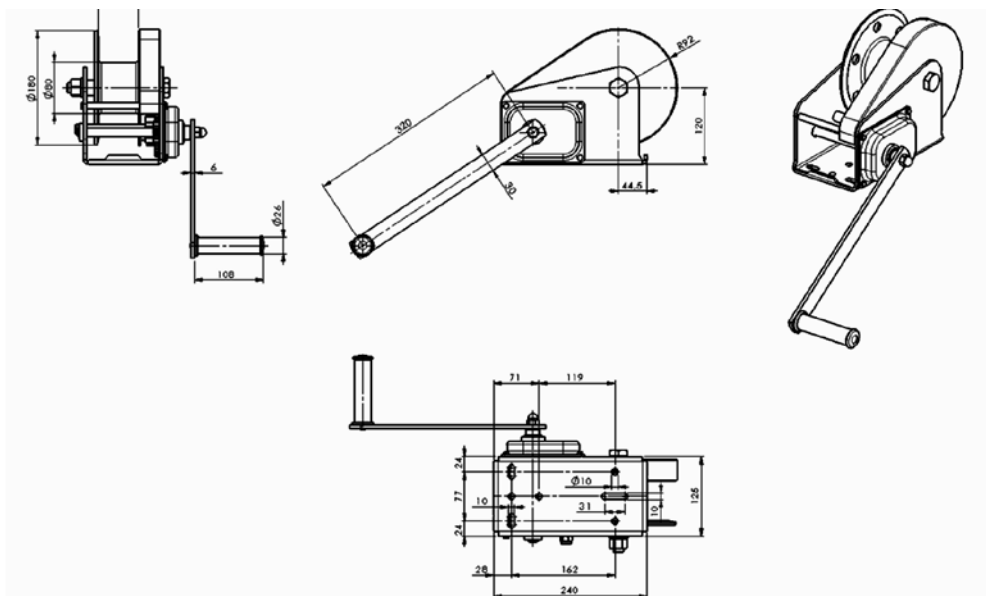

Type	Mounting	Material finish	Remarks
HW200 GR	Floor, 3x M8 class 8.8	Painted finish	RAL 7038 (dark grey)
HW200 SS	Floor, 3x M8 class 8.8	Stainless steel finish	
HW800 SS	Floor, 4x M8 class 8.8	Stainless steel finish	

Technical specifications		HW200	HW800
Capacity 1st cable layer	kg	200	800
Capacity last cable layer	kg	86	491
Crankforce 1st cable layer	daN	8	13
Hoisting length one rotation, 1st layer	mm	40	26
Max. cable storage (one cable drum)	m	31	15
Diameter cable	mm	4	8
Min. breaking load cable	kN	6	24
Own weight	kg	4	10

subject to changes

Form more information: www.gebuwin.com

Low speed electric worm gear winch LS3000-7500

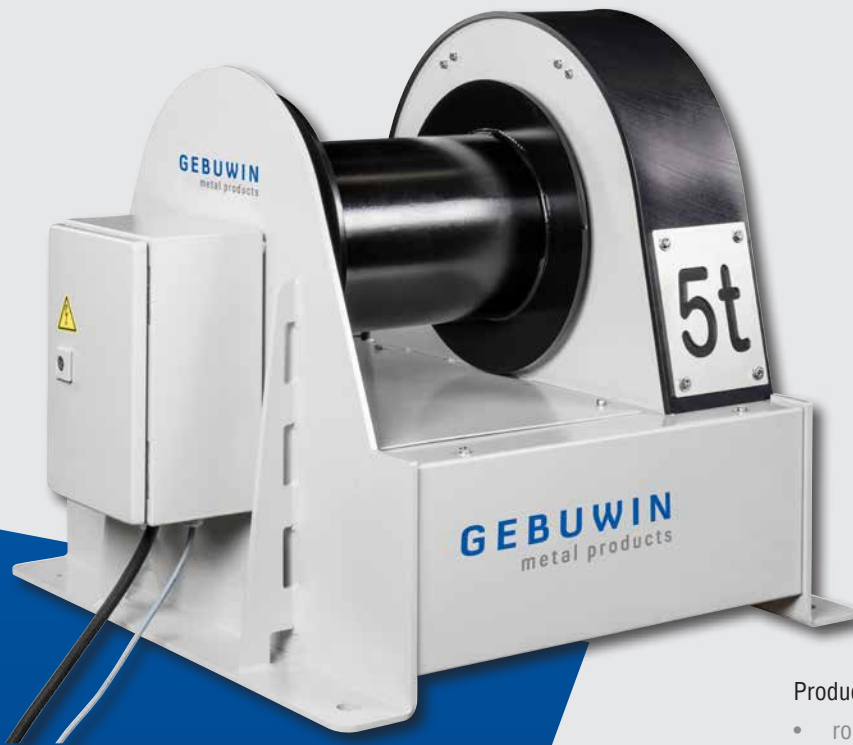

Low speed electric worm gear winch

230 V or 400 V-50 Hz



Product specifications:

- robust and safe electric pulling winch 400 V
- in compliance with EN 14492
- protection classification electric IP55/mechanical IP54
- electric insulation class F
- operation mode S3 (= low frequency use)
- mechanical overload protection
- thermal protection electric motor
- low voltage (24 V) pendant switch with 2 m cable
- including 2 m power cable with 16A CEE plug
- automatic grease system for the worm gearing
- paint thickness is 60 - 80 micron in 1 layer and in compliance with DIN/ISO 12944, C1M

Options:

- limit switch (required for hoisting application)
- grooved drum
- multiple cable drum compartments
- 230 V - 50 Hz

Accessories:

- steel or stainless steel wire ropes

GEBUWIN
metal products

Industrieweg 6, 7102 DZ Winterswijk, The Netherlands
Telephone: +31(0)543 532600 Email: info@gebuwin.com
For more information: www.gebuwin.com



Technical specifications LS3000-7500

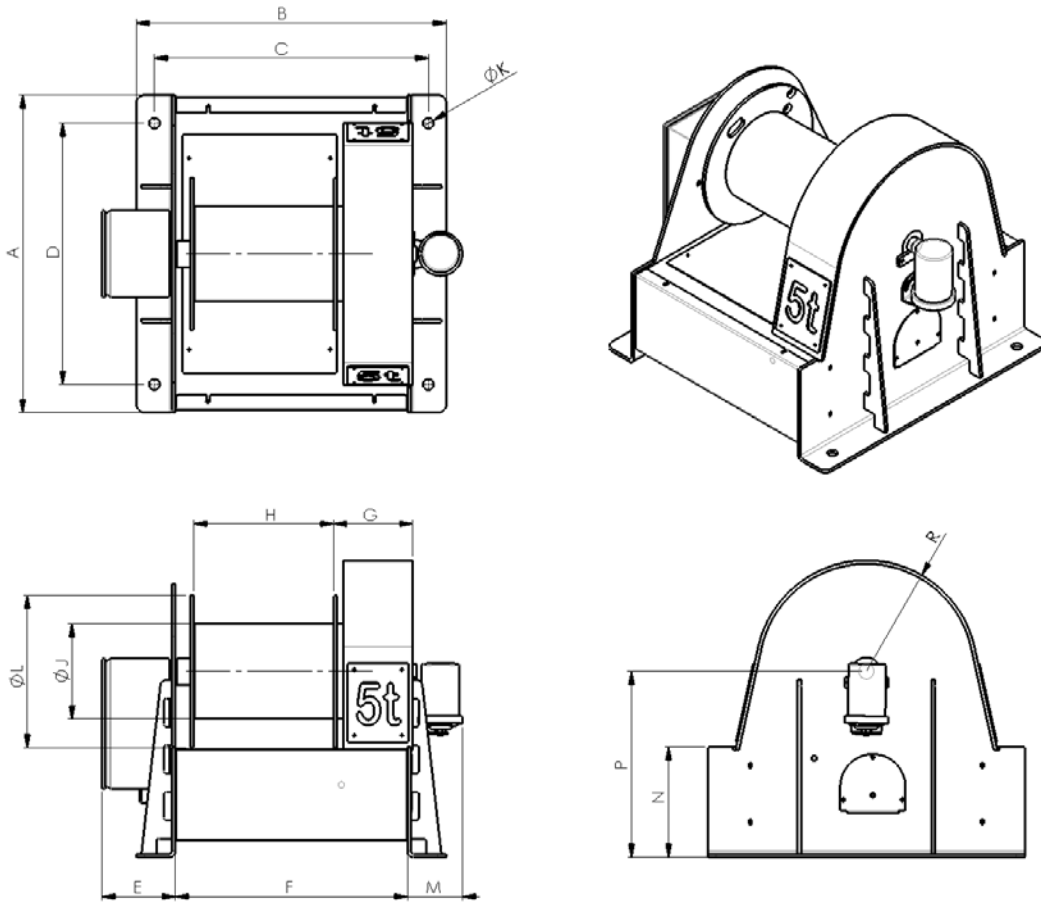

Type	Mounting	Material finish	Remarks
LS3000 - 7500 GR / D	Floor, 4x M20 class 8.8	Painted finish	RAL 7035 (grey)

Dimensions (mm)	A	B	C	D	E	F	G	H	J	K	L	M	N	P	R
LS3000	700	600	630	600	169	534	183	324	168	25	275	126	254	390	223
LS5000	730	714	630	600	169	534	183	322	219	25	351	126	254	427	255
LS7500	750	854	764	650	171	614	204	370	245	25	425	128	275	498	327

Technical specifications		LS3000	LS5000	LS7500
Capacity 1st cable layer	kg	3000	5000	7500
Capacity last cable layer (3)	kg	2369	3959	5830
Cable speed 1st cable layer	m/min	0,5	0,4	0,3
Min. breaking load cable	kN	90	150	225
Diameter cable	mm	14	18	22
Max. cable storage (pulling)	m	40	39	42
Max. cable storage (hoisting, incl. limit switch)	m	10	10	10
Grease unit (grease EP2, approx. 1 year)	cc	240	240	240
Motor output	kW	0,55	0,75	0,75
Current	A	1,6	2	2
Own weight	kg	166	216	329

subject to changes

Form more information: www.gebuwin.com

Electric worm gear winch EW125-3200

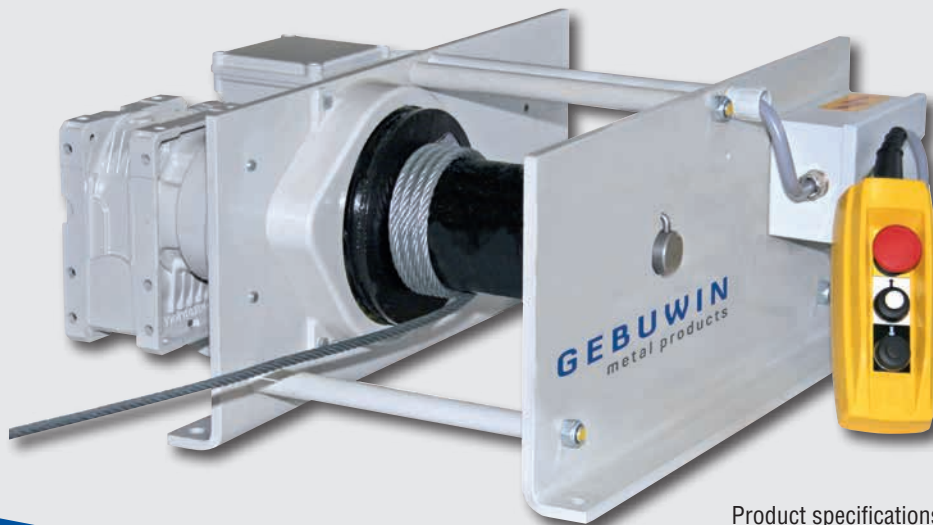

Electric worm gear winch

230 V or 400 V-50 Hz



Product specifications:

- robust and safe electric pulling winch
- maintenance free ball bearings
- protection classification IP55, insulation class B
- standard overload protection starting from 1000 kg
- standard 1 meter pendant control switch
- operation mode S3 -40% - 120 c/h

Options:

- available as electric hoisting winch (limitswitch and low voltage control are required)
- increase of cable storage per 10 m
- grooved drum
- multiple cable drum compartments
- disengaging clutch (except for 125 kg model)
- wall mounted control switch
- operational limit switch for external installation
- electric overload protection for 125 kg - 990 kg
- low voltage control 42 V control
- double speed (), only possible for
- radio control
- frequency control
- protection classification up to IP66
- ATEX certified  II 3 GD T4, zone 2 and 22

Accessories:

- steel or stainless steel wire ropes

GEBUWIN
metal products

Industrieweg 6, 7102 DZ Winterswijk, The Netherlands
Telephone: +31(0)543 532600 Email: info@gebuwin.com
For more information: www.gebuwin.com



Technical specifications EW125-3200

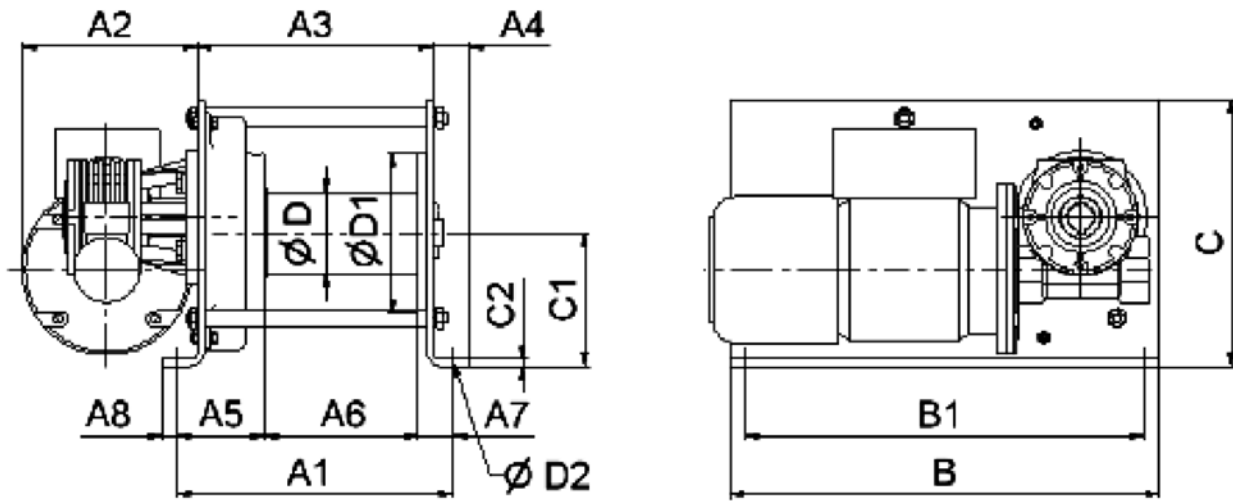

Type	Mounting	Material finish	Remarks
EW125 D / 230 V or 400 V	Floor, 4x M8 class 8.8	Painted finish	RAL 7035 (grey)
EW250 D / 230 V or 400 V	Floor, 4x M10 class 8.8	Painted finish	RAL 7035 (grey)
EW500 D / 230 V or 400 V	Floor, 4x M10 class 8.8	Painted finish	RAL 7035 (grey)
EW990 D / 230 V or 400 V	Floor, 4x M12 class 8.8	Painted finish	RAL 7035 (grey)
EW1000 D / 230 V or 400 V	Floor, 4x M12 class 8.8	Painted finish	RAL 7035 (grey)
EW2000 D / 230 V or 400 V	Floor, 4x M16 class 8.8	Painted finish	RAL 7035 (grey)
EW3200 D / 400 V	Floor, 4x M16 class 8.8	Painted finish	RAL 7035 (grey)

Dimensions (mm)	A1	A2	A3	A4	A5	A6	A7	A8	B	B1	C	C1	C2	D	D1	D2
EW125 D / 230 V or 400 V	205	195/165	171	30	43	135	27	13	405	375	215	140	4	60	130	9
EW250 D / 230 V or 400 V	260	195/165	222	34	78	150	32	15	405	375	250	125	6	60	150	11
EW500 D / 230 V or 400 V	260	195/165	222	34	82	145	33	15	405	375	250	125	6	76	150	11
EW990 D / 230 V or 400 V	345	240/216	289	45	99	198	48	17	575	535	270	155	10	108	180	13
EW1000 D / 230 V or 400 V	345	240/216	289	45	99	198	48	17	575	535	270	155	10	108	180	13
EW2000 D / 230 V or 400 V	440	240/216	358	61	173	200	67	20	600	550	385	171	15	146	245	17
EW3200 D / 400 V	525	198	443	61	193	257	75	20	600	550	405	191	15	216	370	17

Technical specifications		EW125	EW250	EW500	EW990	EW1000	EW2000	EW3200
Capacity 1st cable layer	kg	125	250	500	990	1000	2000	3200
Capacity last cable layer	kg	90	180	340	780	780	1560	2500
Cable speed 1st cable layer (230 V)	m/min	7,8 (15)	5 (10)	2,5 (5)	4,5	4,5	4,5	-
Cable speed 1st cable layer (400 V)	m/min	7,8 (15)	5 (10)	2,5 (5)	4,5 (9)	4,5 (9)	4,5	4,5
Diameter cable	mm	4	4	6	8	8	11	16
Max. cable storage	m	32	35	30	30	30	30	37
Min. breaking load cable	kN	5	9	18	36	36	70	114
Motor output (230 V)	kW	0,37 (0,75)	0,37 (0,75)	0,37 (0,75)	1,3 (2,6)	1,3 (2,6)	2,6	-
Motor output (400 V)	kW	0,37 (0,75)	0,37 (0,75)	0,37 (0,75)	1,3	1,3	2,6	3
Current (230 V)	A	4 (5,2)	4 (5,2)	4 (5,2)	9,1	9,1	9,1	-
Current (400 V)	A	1,1 (1,9)	1,1 (1,9)	1,1 (1,9)	3,2 (6)	3,2 (6)	6	7
Own weight	kg	27	37	40	88	88	160	210

() = version with double cable speed
subject to changes

Form more information: www.gebuwin.com

Electric planetary winch EP2000-20000

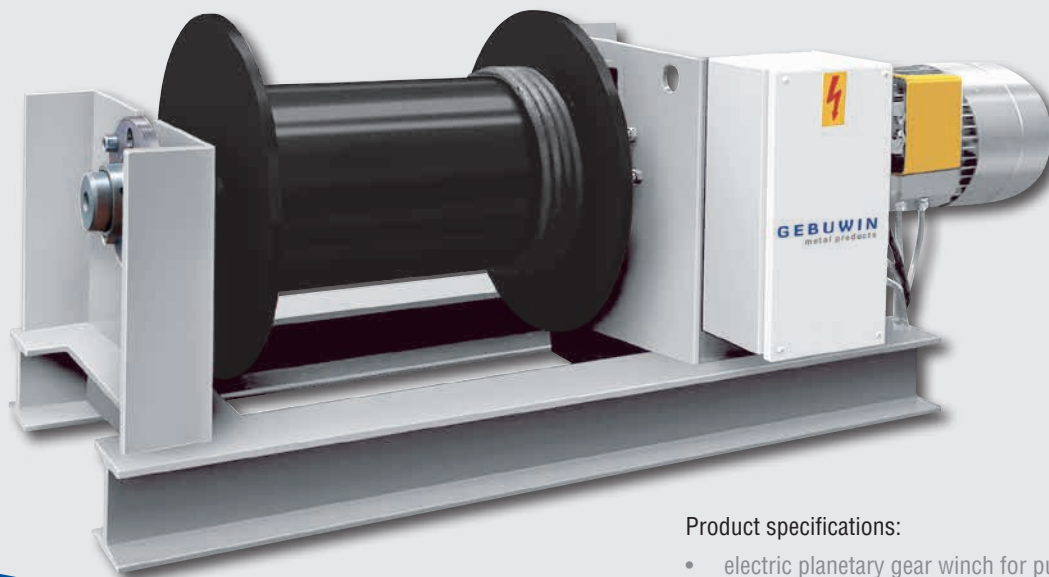

Electric planetary winch

400 V-50 Hz

Product specifications:

- electric planetary gear winch for pulling
- precision drive by planetary gear
- high performance
- robust construction
- large wire rope capacity

Options:

- available as electric hoisting winch (limitswitch and low voltage control are required)
- available in multiple speeds (S1, S2 and S3)
- grooved drum
- separation partition and/or second wire rope fastening on the drum
- second brake as safety brake
- pressure roller
- rope spooling guide
- slack rope monitoring
- manual drive device
- counter for operation hours
- other speeds, capacities and frequencies
- radio control
- low voltage control
- continuous wire rope speed
- protection classification up to IP66
- drum protection cover
- disengaging clutch
- ATEX certified  II 3 GD T4, zone 2 and 22
- and many more

GEBUWIN
metal products

Industrieweg 6, 7102 DZ Winterswijk, The Netherlands
Telephone: +31(0)543 532600 Email: info@gebuwin.com
For more information: www.gebuwin.com



Technical specifications EP2000-20000

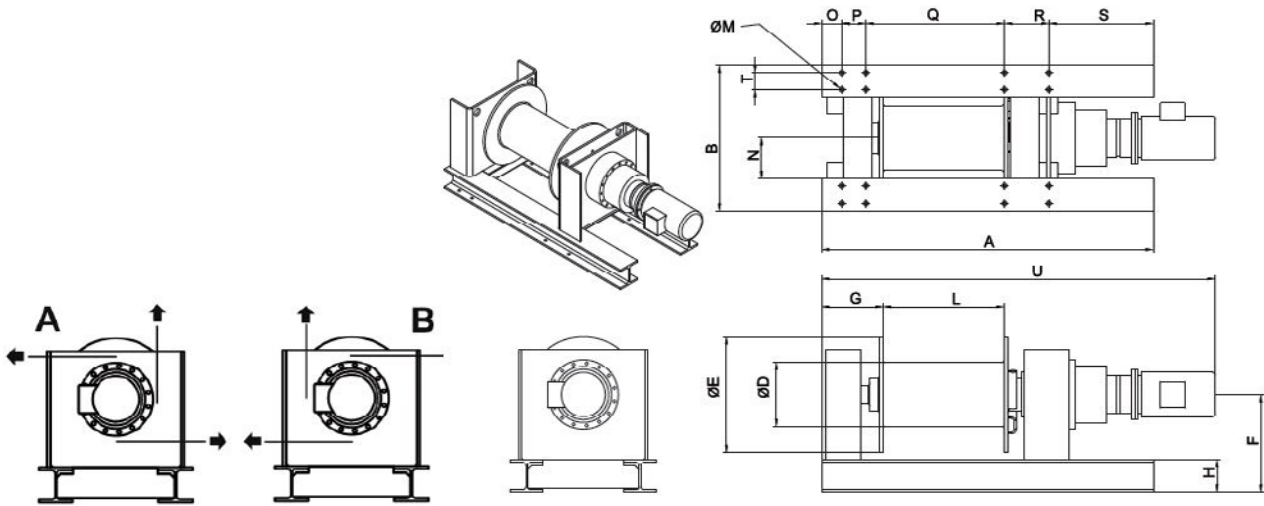

Dimensions (mm)	A	B	D	E	F	G	H	L	M	N	O	P	Q	R	S	T	U
EP2000 / D / S1	1450	544	133	300	320	215	100	530	13	172	70	100	700	100	480	56	1530
EP3200 / D / S1	1450	544	159	320	320	215	100	610	13	172	70	100	700	100	480	56	1650
EP4000 / D / S1	1450	544	178	350	320	215	100	580	13	172	70	100	700	100	480	56	1620
EP5000 / D / S1	1530	620	203	400	370	204	120	610	17	190	90	75	700	75	590	70	1720
EP6300 / D / S1	1530	620	219	430	370	204	120	610	17	190	90	75	700	75	590	70	1790
EP8000 / D / S1	1650	724	254	510	485	301	160	600	23	202	100	120	690	220	520	86	1900
EP10000 / D / S1	1650	724	279	550	485	301	160	600	23	202	100	120	690	220	520	86	1900
EP12500 / D / S1	1650	724	318	610	485	301	160	600	23	202	100	120	690	220	520	86	2040
EP16000 / D / S1	1850	1000	356	685	595	378	220	600	25	280	150	200	700	200	600	120	2140
EP20000 / D / S1	1850	1000	394	760	595	378	220	600	25	280	150	200	700	200	600	120	2310

Type	Capacity layer	Wirerope		Motor		Wirerope speed		Wirerope storage		Own weight
	kg	mm	kN	kW	A	1st layer	5th	1st layer	5th	(no wirerope)
						m/min	m/min	m	m	kg
EP2000 / D / S1	2000	10	71	1,4/5,5	5,6/12,5	3,5/1,4	5,5/22	20	135	260
EP3200 / D / S1	3200	12	114	1,4/5,5	5,6/12,5	2/9	3,5/14	23	160	305
EP4000 / D / S1	4000	13	142	1,4/5,5	5,6/12,5	1,5/6	2,5/10	22	150	310
EP5000 / D / S1	5000	14	178	1,4/5,5	5,6/12,5	1/5	2/7,5	25	165	415
EP6300 / D / S1	6300	16	224	1,4/5,5	5,6/12,5	1/4	2/7	20	155	455
EP8000 / D / S1	8000	18	284	1,4/5,5	5,6/12,5	1/3,5	1,4/5,5	22	155	685
EP10000 / D / S1	10000	20	355	1,4/5,5	5,6/12,5	0,7/2,5	1,1/4,3	22	155	700
EP12500 / D / S1	12500	22	444	1,4/5,5	5,6/12,5	0,6/2,2	0,9/3,5	22	160	815
EP16000 / D / S1	16000	25	568	1,4/5,5	5,6/12,5	0,5/1,8	0,7/2,8	22	160	1210
EP20000 / D / S1	20000	28	710	2/8,5	6,5/18,2	0,5/2,1	0,8/3,2	22	160	1320

subject to changes

Form more information: www.gebuwin.com

Drill worm gear winch DW1000



Drill worm gear winch

Product specifications:

- robust and safe hoisting and pulling winch
- in compliance with EN13157, DIN15020
- static safety factor 4
- right angled worm transmission and spur gearing
- cable outlet upwards, downwards or at rear
- drill and hand operated
- adjustable crank with ergonomic grip
- load pressure break with ratchet system
- transmission box IP54
- automatic grease system for the worm gearing
- paint thickness is 60 - 80 micron in 1 layer and in compliance with DIN/ISO 12944, C1M

Options:

- grooved drum
- multiple cable drum compartments

Accessories:

- steel or stainless steel wire ropes



GEBUWIN
metal products

Industrieweg 6, 7102 DZ Winterswijk, The Netherlands
Telephone: +31(0)543 532600 Email: info@gebuwin.com
For more information: www.gebuwin.com

Technical specifications DW1000

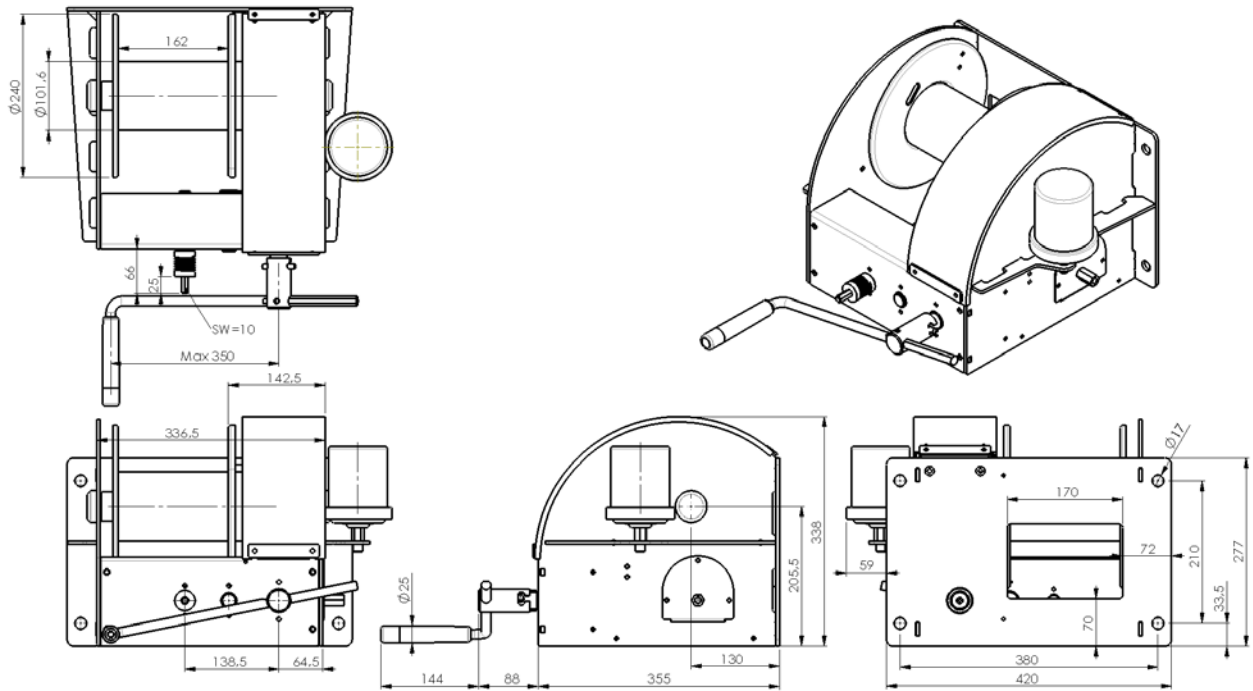

Type	Mounting	Material finish	Remarks
DW1000 GR / D	Wall, 4x M12 class 8.8	Painted finish	RAL 7035 (grey)

Technical specifications			DW1000
Capacity 1st cable layer		kg	1000
Capacity last cable layer		kg	527
Hand operated, 1st layer	Crank force	kg	11
	Hoisting length by one rotation	mm	9 (approx. 0,23 m/min)
Drill operated, 1st layer	Torque in going shaft	Nm	ca. 6
	Max. input rotation speed drill	rpm	650
	Cable speed	m/min	0,6
Battery driven grease system	DC 4,5-5 V, grease EP	cc	125 (approx. for 1 year)
Max. cable storage		m	63
Diameter cable		mm	8
Min. breaking load cable		kN	30
Own weight		kg	39

subject to changes

Form more information: www.gebuwin.com

Battery drill worm gear winch WA200



Battery drill worm gear winch

Product specifications:

- robust and safe hoisting and pulling winch operated with battery drill
- static safety factor 4
- flexible coupling attachment for battery drill
- self braking worm gear system
- suitable for wall or floor (console) mounting
- suitable for short hoisting lengths
- maintenance free aluminum closed gear box
- in compliance with EN13157 and DIN 15020
- painted frame with thickness 60 - 80 micron in 1 layer and zinc-plated finished cable drum

Accessories:

- steel or stainless steel wire ropes



GEBUWIN
metal products

Industrieweg 6, 7102 DZ Winterswijk, The Netherlands
Telephone: +31(0)543 532600 Email: info@gebuwin.com
For more information: www.gebuwin.com



Technical specifications WA200

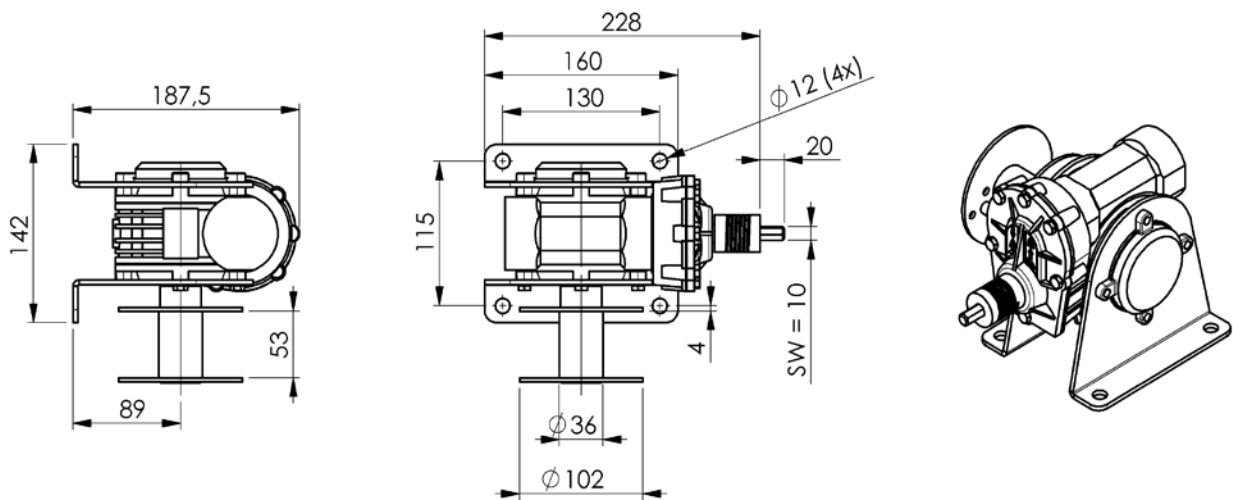
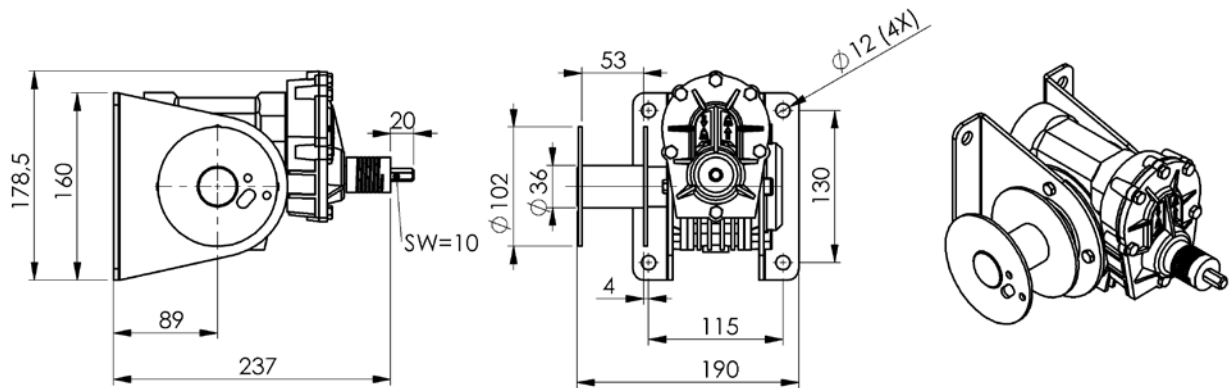

Type	Mounting	Material finish	Remarks
WA200 GR / D	Wall / Floor, 4x M10 class 8.8	Painted finish	RAL 7035 (grey)

Technical specifications		WA200
Capacity 1st cable layer	kg	200
Capacity last cable layer (7)	kg	90
Max. speed drill driver	rpm	1400
Six-angled adapter	mm	10
Max. hoisting speed	mm/min	800
Hoist length with 200 kg and cordless drill 14,4V - 3 Ah	m	8
Cable capacity	m	18
Diameter cable	mm	4
Min. breaking load cable	kN	6
Own weight	kg	6

subject to changes

Form more information: www.gebuwin.com

Electric chain hoist EH125-2000 with eye or hook



Electric chain hoist



Product specifications:

- with eye (E) or hook (H)
- durable, safe and easy to use
- aluminium cast body, compact, light and robust, control panel made with shock resistant plastic
- corrosion resistant electromagnetic brake
- very smooth transmission, vibration-free and low noise
- three-phase motor with two speeds (S1 and S2), insulation class F
- power supply 400 V - 50 Hz /60 Hz
- low voltage control 48 V
- overload limiter
- galvanized chain class DAT (G 80) (EN818-7)
- standard length of chain is 3 m
- durable chain container
- ergonomic push button control, IP65
- standard push button length 2 m
- protection IP55
- operation humidity 85% or less
- operating temperature -10 °C / +40 °C
- operating mode S3

Options:

- limit switch for vertical movement
- radio control
- increase of chain storage

GEBUWIN
metal products

Industrieweg 6, 7102 DZ Winterswijk, The Netherlands
Telephone: +31(0)543 532600 Email: info@gebuwin.com
For more information: www.gebuwin.com



Technical specifications EH125-2000

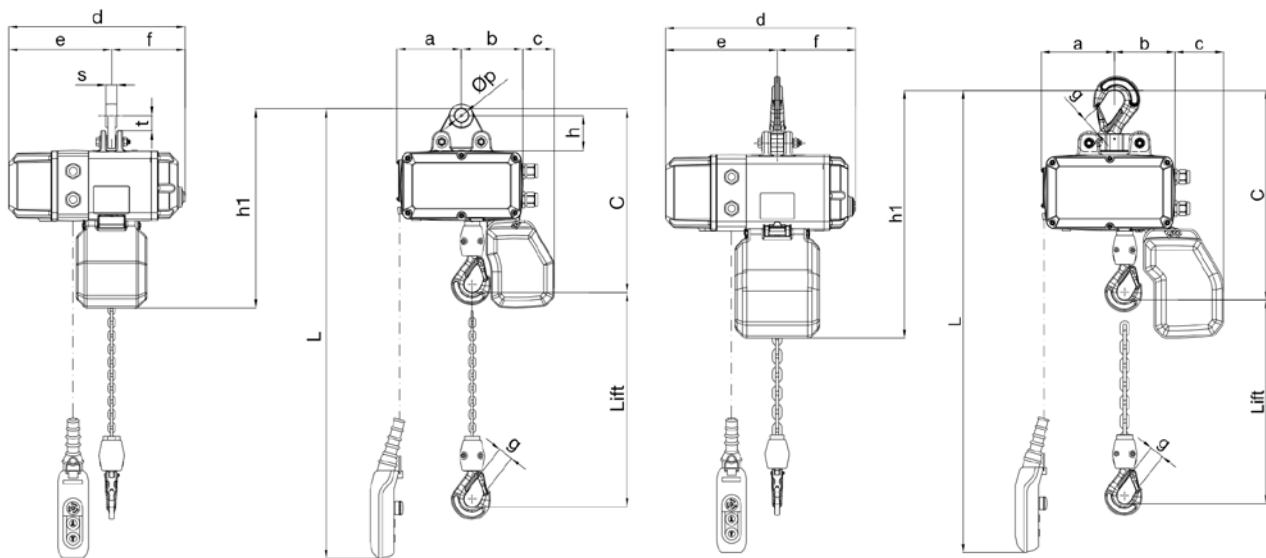

Dimensions (mm)	Minimum headroom C	a	b	c	d	e	f	g	h	h1*	s	t	Ø p
EH125 E / S1	420	148	140	72	404	235	169	25	80	455	25	35	30,5
EH250 E / S1 and S2	420	148	140	72	404	235	169	25	80	455	25	35	30,5
EH500 E / S1 and S2	420	148	140	72	404	235	169	25	80	455	25	35	30,5
EH1000 E / S1	456	148	140	72	404	235	169	25	80	455	25	35	30,5
EH1000 E / S2	454	174	144	116	452	266	186	25	92	545	30	36,5	36,5
EH2000 E / S1	541	174	144	116	452	266	186	34	92	545	30	36,5	36,5
EH125 H / S1	445	148	140	72	404	235	169	25	-	480	-	-	-
EH250 H / S1 and S2	445	148	140	72	404	235	169	25	-	480	-	-	-
EH500 H / S1 and S2	445	148	140	72	404	235	169	25	-	480	-	-	-
EH1000 H / S1	480	148	140	72	404	235	169	25	-	480	-	-	-
EH1000 H / S2	500	174	144	116	452	266	186	25	-	590	-	-	-
EH2000 H / S1	585	174	144	116	452	266	186	34	-	590	-	-	-

* short type chain container (up to 11 m chain)

Technical specifications	Chain		Lifting speed	Lifting motor output	Power supply	Classification std.	Weight
	mm	n°	m/min.	kW	V	FEM	kg
EH125 E and H / S1	5	1	8/2	0,09/0,36	380-415	2m	35
EH250 E and H / S1	5	1	5/1,25	0,09/0,36	380-415	3m	35
EH250 E and H / S2	5	1	8/2	0,09/0,36	380-415	1Am	35
EH500 E and H / S1	5	1	5/1,25	0,18/0,75	380-415	1Am	35
EH500 E and H / S2	5	1	8/2	0,18/0,75	380-415	1Am	35
EH1000 E and H / S1	5	2	4/1	0,18/0,75	380-415	1Am	37
EH1000 E and H / S2	7	1	8/2	0,45/1,90	380-415	1Am	58
EH2000 E and H / S1	7	2	4/1	0,45/1,90	380-415	1Am	61

subject to changes

Form more information: www.gebuwin.com

Electric chain hoist EH125-2000 (electric) trolley



Electric chain hoist



Product specifications:

- as plain trolley (T) or electric trolley (ET)
- aluminium cast body, compact, light and robust, control panel made with shock resistant plastic
- corrosion resistant electromagnetic brake
- very smooth transmission, vibration-free and low noise
- three-phase motor with two speeds (S1 and S2), insulation class F
- power supply 400 V - 50 Hz /60 Hz
- low voltage control 48 V
- overload limiter
- galvanized chain class DAT (G 80) (EN818-7)
- standard length of chain is 3 m
- durable chain container
- ergonomic push button control, IP65
- standard push button length 2 m
- protection IP55
- operation humidity 85% or less
- operating temperature -10 °C / +40 °C
- operating mode S3
- wheel profile suitable for flat or tapered beams
- safety lugs and rubber pads
- limit switch horizontal movement (electric trolley)

Options:

- limit switch for vertical movement
- radio control
- increase of chain storage

GEBUWIN
metal products

Industrieweg 6, 7102 DZ Winterswijk, The Netherlands
Telephone: +31(0)543 532600 Email: info@gebuwin.com
For more information: www.gebuwin.com



Technical specifications EH125-2000

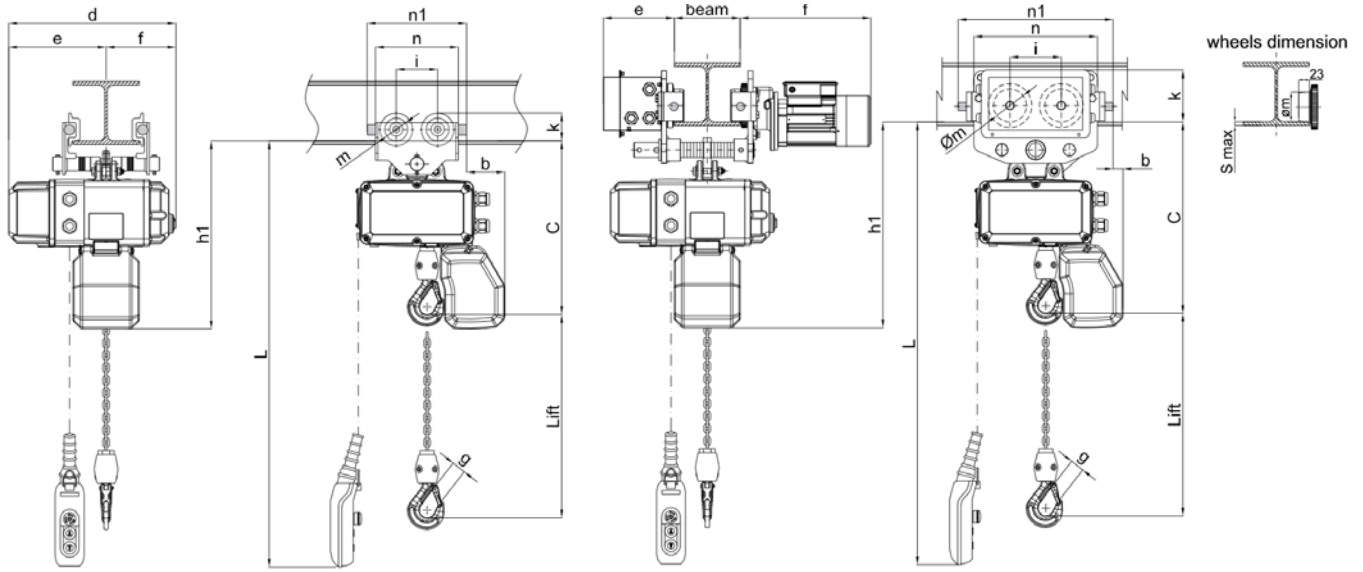

Dimensions (mm)	Minimum headroom C	b	d	e	f	g	h1*	i	m	n	n1	k	S max
EH125 T / S1	425	92	404	235	169	25	460	100	55	200	240	67	-
EH250 T / S1 and S2	425	92	404	235	169	25	460	100	55	200	240	67	-
EH500 T / S1 and S2	425	92	404	235	169	25	460	100	55	200	240	67	-
EH1000 T / S1	500	69	404	235	169	25	498	120	78	246	286	87	-
EH1000 T / S2	462	117	452	236,5	186,5	25	555	120	78	246	286	87	-
EH2000 T / S1	555	117	452	236,5	186,5	34	560	132	80	276	316	94	-
EH125 ET / S1	465	24	-	172	317	25	500	124,5	80	300	376	125	25
EH250 ET / S1 and S2	465	24	-	172	317	25	500	124,5	80	300	376	125	25
EH500 ET / S1 and S2	465	24	-	172	317	25	500	124,5	80	300	376	125	25
EH1000 ET / S1	500	24	-	172	317	25	500	124,5	80	300	376	125	25
EH1000 ET / S2	580	72	-	172	317	25	584	124,5	80	300	376	125	25
EH2000 ET / S1	667	72	-	172	317	34	584	124,5	80	300	376	125	25

* short type chain container (up to 11 m chain)

Technical specifications	Chain mm	n°	Lifting speed m/min.	Lifting motor output kW	Power supply V	Classification std. FEM	Beam width mm	Weight kg
EH125 T / S1	5	1	8/2	0,09/0,36	380-415	2m	62-300	41
EH250 T / S1	5	1	5/1,25	0,09/0,36	380-415	3m	62-300	41
EH250 T / S2	5	1	8/2	0,09/0,36	380-415	1Am	62-300	41
EH500 T / S1	5	1	5/1,25	0,18/0,75	380-415	1Am	62-300	41
EH500 T / S2	5	1	8/2	0,18/0,75	380-415	1Am	62-300	41
EH1000 T / S1	5	2	4/1	0,18/0,75	380-415	1Am	80-300	48
EH1000 T / S2	7	1	8/2	0,45/1,90	380-415	1Am	80-300	70
EH2000 T / S1	7	2	4/1	0,45/1,90	380-415	1Am	106-300	80
EH125 ET / S1*	5	1	8/2	0,09/0,36	-	2m	55-300	76
EH250 ET / S1*	5	1	5/1,25	0,09/0,36	-	3m	55-300	76
EH250 ET / S2*	5	1	8/2	0,09/0,36	-	1Am	55-300	76
EH500 ET / S1*	5	1	5/1,25	0,18/0,75	-	1Am	55-300	76
EH500 ET / S2*	5	1	8/2	0,18/0,75	-	1Am	55-300	76
EH1000 ET / S1*	5	2	4/1	0,18/0,75	-	1Am	55-300	85
EH1000 ET / S2*	7	1	8/2	0,45/1,90	-	1Am	60-300	106
EH2000 ET / S1*	7	2	4/1	0,45/1,90	-	1Am	60-300	116

* Trolley speed: 10-20-20/5 m/min. -- Trolley motor output: 0,18-0,25-0,12/0,03 kW

subject to changes

Form more information: www.gebuwin.com

Swivel davit SD125-250-500



Swivel davit



Product specification:

- robust and safe hoisting davit
- ready to use in 5 seconds
- integrated winch and cable in an ergonomic modern design
- easy to transport, only 25 kg
- 360 degrees rotation over a built in pivot bearing
- maintenance free
- including 8 meter wire rope (d5 mm) with hook
- adjustable crank
- paint application in compliance with DIN/ISO 12994, C1M
- integrated winch in compliance with EN13157, DIN15020 and EX types ATEX 114 (94/9/EG)

Options:

- zinc plated finish (6 - 8 micron)
- stainless steel grade SAE 316
- ATEX certified  II 3 GD T3, zone 2 and 22
- other dimensions on request

Accessories:

- floor, wall and in-cement floor sockets
- carry bag and protection cover

GEBUWIN
metal products

Industrieweg 6, 7102 DZ Winterswijk, The Netherlands
Telephone: +31(0)543 532600 Email: info@gebuwin.com
For more information: www.gebuwin.com



Technical specifications SD125-250-500

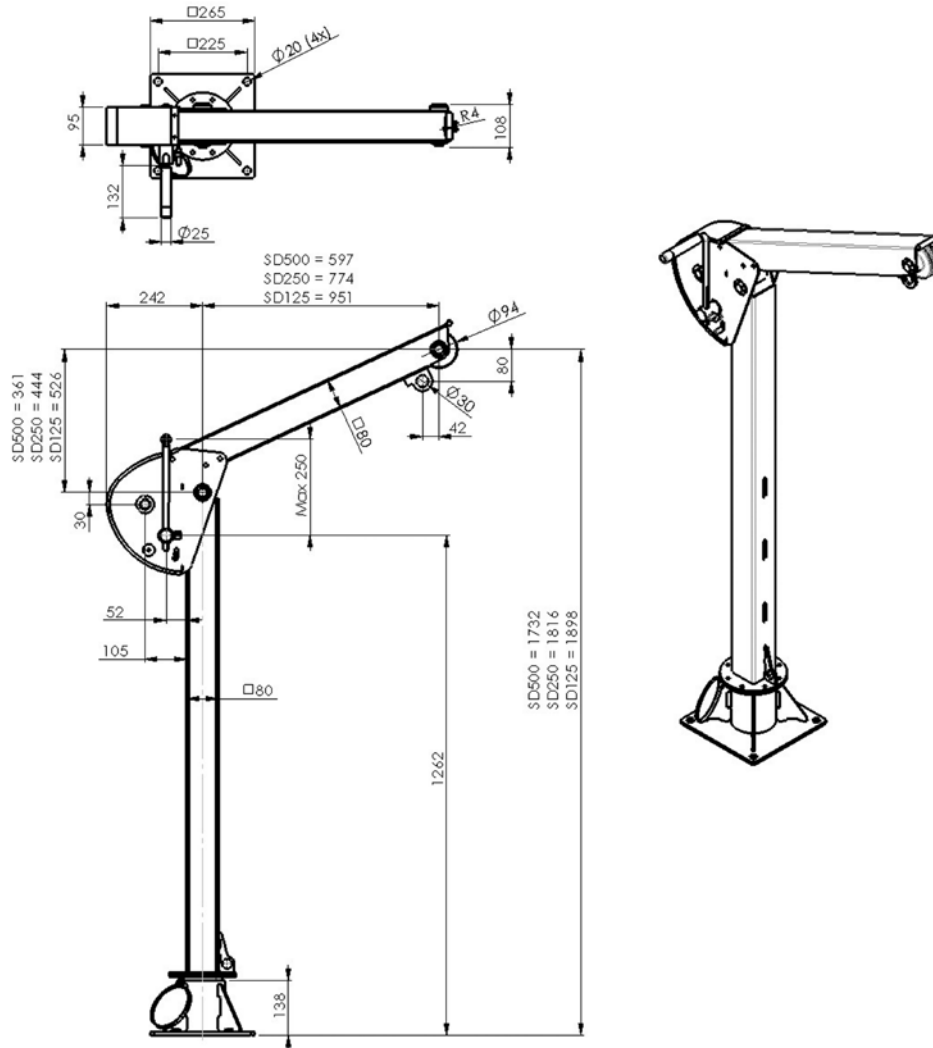

Type	Mounting	Material finish	Remarks
SD125, SD250, SD500 GR	Floor, 4x M18 class 8.8	Zinc-plated finish	RAL 7035 (grey)
SD125, SD250, SD500 EV	Floor, 4x M18 class 8.8	Zinc-plated finish	
SD125, SD250, SD500 SS (minimum order of 5)	Floor, 4x M18 class 8.8		
Swivel davit floor-socket EV	Floor	Zinc-plated finish	Including cover
Swivel davit wall-socket EV	Wall	Zinc-plated finish	Including cover
Swivel davit in-cement-socket EV	Cement	Zinc-plated finish	Including cover

Technical specifications		SD125	SD250	SD500
1st cable layer	kg	125	250	500
Last cable layer (7)	kg	125	250	268
Crankforce 1st cable position	daN	10	10	10
Hoisting length one rotation, 1st layer	mm	20	20	20
Max. cable storage *	m	24	24	13
Diameter cable *	mm	4	4	5
Min. breaking load cable	kN	4	7,5	15
Own weight Swivel Davit	kg	25	25	25
Own weight floor-socket	kg	7	7	7
Own weight wall-socket	kg	8	8	8
Own weight in cement-socket	kg	3	3	3

* All models standard delivered with 5 mm wire rope, length 8 m.

Spur gear box TK1000-1001-1500-1501



Spur gear box



Product specifications:

- robust and safe spur gear box
- protection classification IP54
- maintenance free bearings
- static safety factor 4
- TK1000-1500 with crank and load pressure brake
- TK1001-1501 with input and output shaft

Options:

- ATEX certified  II 3 GD T3, zone 2 and 22
- stainless steel gearbox

Accessories:

- steel or stainless steel wire ropes

GEBUWIN
metal products

Industrieweg 6, 7102 DZ Winterswijk, The Netherlands
Telephone: +31(0)543 532600 Email: info@gebuwin.com
For more information: www.gebuwin.com



Technical specifications TK1000-1500

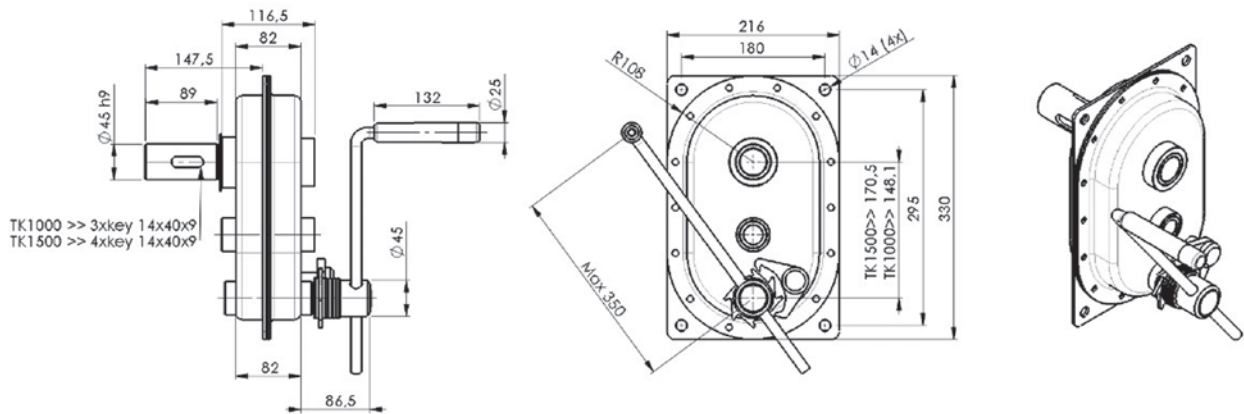

Technical specifications TK1001-1501

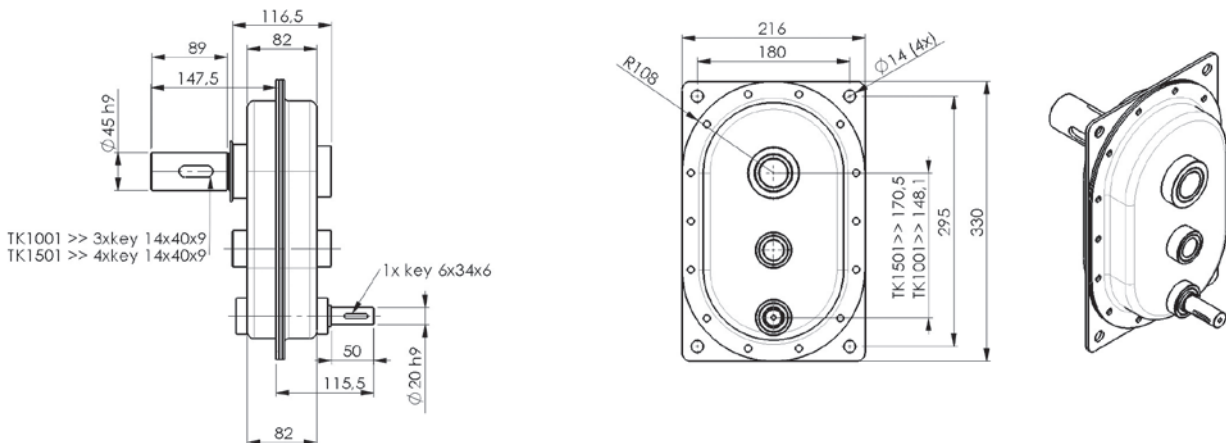

Type	Mounting	Material finish	Remarks
TK1000 - 1500 EV	Wall, 4x M12 class 8.8	Zinc-plated finish	
TK1001 - 1501 EV	Wall, 4x M12 class 8.8	Zinc-plated finish	

Technical specifications	TK1000	TK1500	TK1001	TK1501
Max output torque	Nm	550	840	550
Crankforce	daN	11	12	-
Max input torque	Nm	-	-	38
Max input speed	rpm	-	-	60
Transmission ratio		1:17	1:25,7	1:17
In- / output shaft diameter	mm	- / 45	- / 45	20 / 45
Own weight	kg	16,5	17	16

subject to changes

Form more information: www.gebuwin.com

Pulley block KB150-7500



Pulley block

Product specifications:

- robust design
- suitable for all hand winches
- pulley wheel made of cast iron
- plain bearing

Options:

- pulley wheels also sold separately
- frame in other color possible when ordered in series



GEBUWIN
metal products

Industrieweg 6, 7102 DZ Winterswijk, The Netherlands
Telephone: +31(0)543 532600 Email: info@gebuwin.com
For more information: www.gebuwin.com



Technical specifications KB150-7500

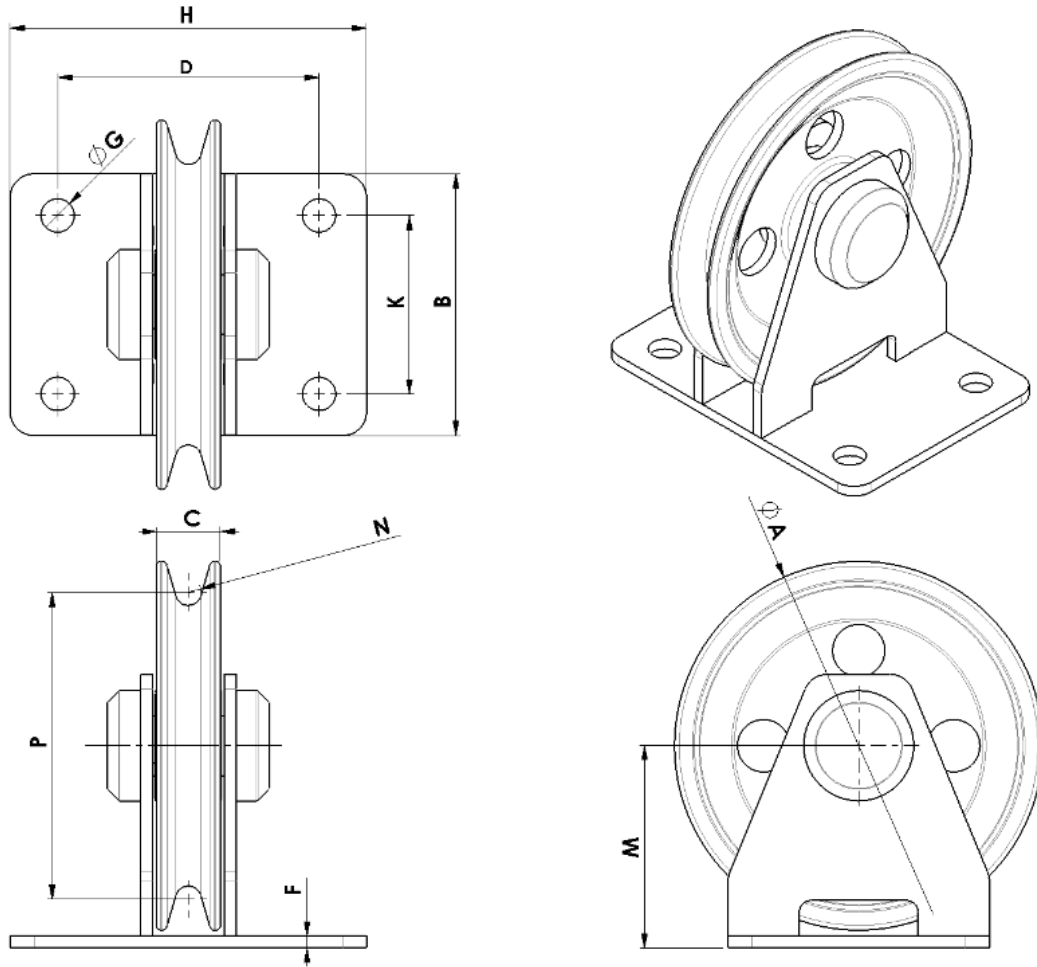

Type	Mounting	Material finish	Remarks
KB150	4x M10 class 8.8	Painted finish	RAL 7035 (grey)
KB300	4x M10 class 8.8	Painted finish	RAL 7035 (grey)
KB600	4x M10 class 8.8	Painted finish	RAL 7035 (grey)
KB1500	4x M12 class 8.8	Painted finish	RAL 7035 (grey)
KB2000	4x M16 class 8.8	Painted finish	RAL 7035 (grey)
KB4000	4x M20 class 8.8	Painted finish	RAL 7035 (grey)
KB7500	4x M20 class 8.8	Painted finish	RAL 7035 (grey)

Dimensions (mm)	A	B	C	D	F	G	H	K	M	N	P
KB150	90	60	18	65	5	11	90	35	54	4,5	72
KB300	100	65	20	70	5	11	100	35	59	5	80
KB600	120	65	28	75	5	13	105	35	69	5,5	98
KB1500	155	110	27	80	6	14	120	75	85	5,5	129
KB2000	220	165	32	105	8	17	155	115	121	8,5	184
KB4000	260	200	40	140	10	21	195	145	143	9,5	222
KB7500	310	240	52	155	12	21	215	180	170	14	250

Technical specifications		KB150	KB300	KB600	KB1500	KB2000	KB4000	KB7500
Max. capacity	kg	150	300	600	1500	2000	4000	7500
Max. diameter cable	mm	4	4	6	10	12	16	22
Own weight	kg	1	1	1,5	3	6,5	11,5	21

subject to changes

Form more information: www.gebuwin.com

Power tool AM5000-EM5000



Power tool



General product specifications:

The pneumatic and electric power tools are intended as an alternative to the manual drive and are only used for brief and non-frequent usage. The combination of a manual winch and electric- or pneumatic power tool is not an alternative to an electric winch.

- robust slow speed drive units
- easy to operate
- reversible rotation
- suitable for use on the worm gear winch models starting from WW1000 up to WW7500
- because of a swift and easy connection system this unit is well equipped to serve various winches on one location

AM5000 product specifications:

- air motor is equipped with a filter and hose fitting
- painted air motor and zinc plated adapter system

EM5000 product specifications:

- electric drill motor 230V-50Hz
- metal gear head with MT4 holder
- including zinc plated winch adapter, additional handle, drift key and suspension eyelet

G E B U W I N
metal products

Industrieweg 6, 7102 DZ Winterswijk, The Netherlands
Telephone: +31(0)543 532600 Email: info@gebuwin.com
For more information: www.gebuwin.com



Technical specifications AM5000-EM5000

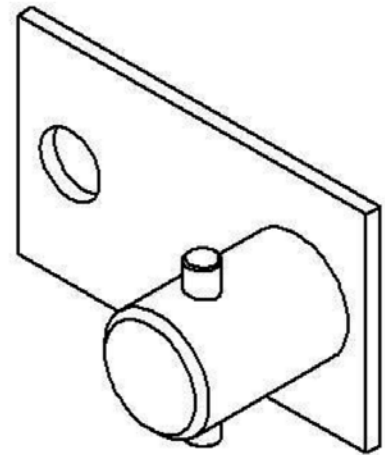
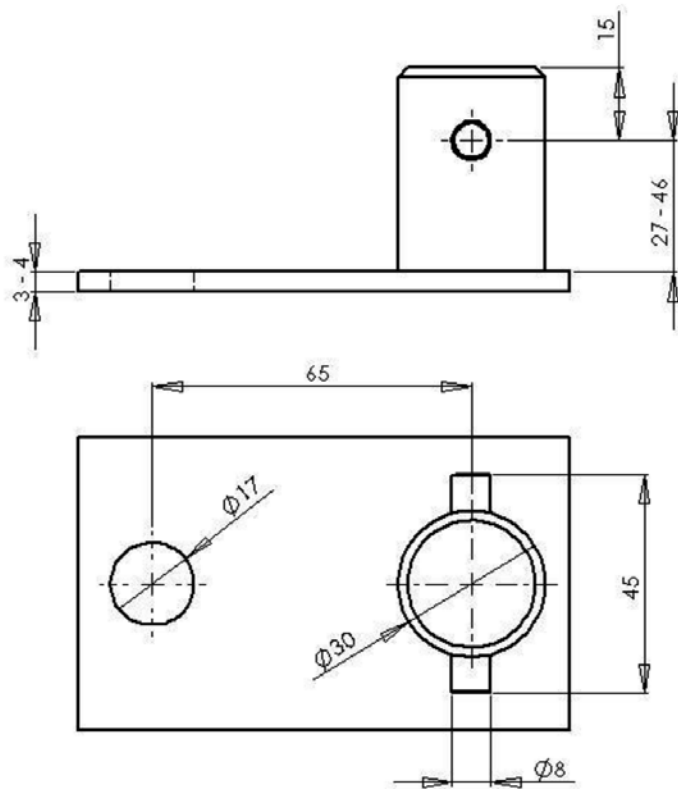

Technical specifications		AM5000	EM5000
Power	W	1200	900
Air pressure	bar	Max. 6-8	-
Voltage - frequency		-	230V-50Hz
Free speed	rpm	140	100
Speed at max. power (torque)	rpm	60 (60-90 Nm)	60 (50-70 Nm)
Dimension L x H x B	mm	545 x 76 x 277	510 x 530 x 150
Own weight	kg	5	13
Air consumption at max power	l/min	2100	-
Min. fitting / hose diameter (inside)	mm	10,4 / 15	-
Cable lenght with plug	m	-	2,5

subject to changes

Form more information: www.gebuwin.com

Wire rope WRH300-7500



Wire rope

Product specifications:

- galvanized steel wire rope
- lay method: right crosslay
- standard version with thimble and talurit end
- standard with safety sling hook and latch
- fused and tapered end
- in compliance with EN12383-4 and EN13157

Options:

- stainless steel 316 wire ropes
- wire rope without sling hook (WRE)
- other specifications are available on demand

GEBUWIN
metal products

Industrieweg 6, 7102 DZ Winterswijk, The Netherlands
Telephone: +31(0)543 532600 Email: info@gebuwin.com
For more information: www.gebuwin.com



Technical specifications WRH300-7500

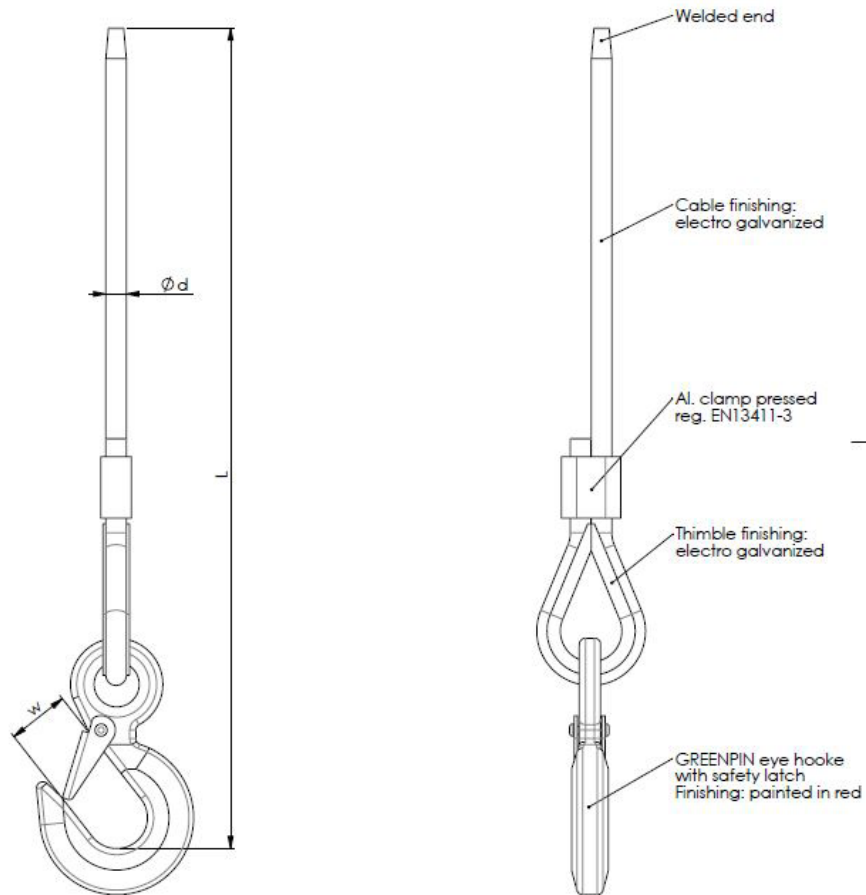

Important: cables suitable for handwinches (EN13157) must have a safety factor of min 3.

Type	Diameter mm	Length m	Width mm	Construction	Max breaking load kN	Pulling force N/mm ²	Hook grade	WLL kg
WRH300 EV	4	13	20	7x19	9,22	1170	Grade 8	1250
WRH300 SS	4	12	26	7x19	7,5	1570	Grade 5	700
WRH600 EV	6	15	20	7x19	20,76	1170	Grade 8	1250
WRH600 SS	6	20	26	7x19	17,0	1570	Grade 5	700
WRH1000 EV	8	20	20	7x19	36,91	1170	Grade 8	1250
WRH1000 SS	8	20	30	7x19	30,0	1570	Grade 5	1200
WRH1500 EV	10	20	22	6x36	52,56	1960	Grade 8	1600
WRH1500 SS	10	20	33	7x19	46,8	1570	Grade 5	1600
WRH2000 EV	12	20	27	6x36	75,69	1960	Grade 8	2500
WRH2000 SS	12	20	37	7x19	67,5	1570	Grade 5	2700
WRH3000 EV	14	20	30	6x36	102,6	1960	Grade 8	3200
WRH3000 SS	14	20	30	7x19	91,8	1570	Grade 8	3200
WRH4000 EV	16	20	37	6x36	135,0	1960	Grade 8	5400
WRH4000 SS	16	20	37	7x19	119,7	1570	Grade 8	5400
WRH5000 EV	18	20	37	6x36	170,1	1960	Grade 8	5400
WRH5000 SS	18	20	37	7x19	162,9	1570	Grade 8	5400
WRH7500 EV	22	20	48	6x36	254,7	1960	Grade 8	8200

subject to changes

Form more information: www.gebuwin.com

GEBUWIN

metal products

Industrieweg 6
7102 DZ Winterswijk
The Netherlands
Telephone: +31(0)543 532600
Email: info@gebuwin.com

www.gebuwin.com